

STANDARD SPROCKET

TYC 25 = (1/4" Pitch)

PITCH 6.35 mm

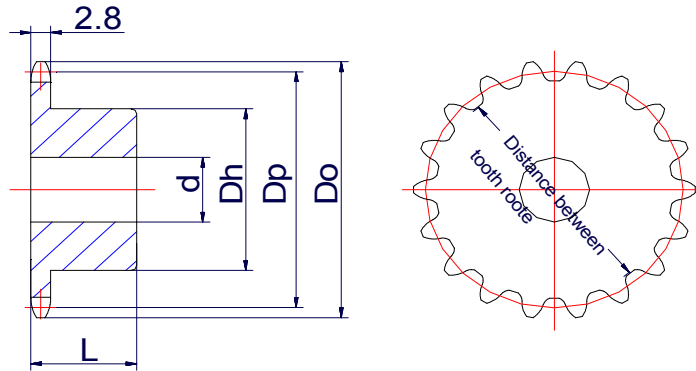

Single Strand B Type

Unit : mm

No. of Teeth	Outside Dia. (Do)	Pitch Dia. (Dp)	Type "B" SINGLE STRAND						Approx. Mass. (kg)	Material	
			HUB			BORE		Approx. Mass. (kg)			Material
			Stock Bore	Diam. (Dh)	Length (L)	(d)					
Min.	Max.										
10	23	20.55	7	14	15	8.5	8.5	0.03	S45C		
11	25	22.54	7	15	15	8.5	8.5	0.03			
12	28	24.53	8	15	15	9.5	9.5	0.03			
13	30	26.53	8	18	15	9.5	10	0.05			
14	32	28.54	8	20	15	9.5	10	0.05			
15	34	30.54	8	20	15	9.5	10	0.05			
16	36	32.55	10	25	15	11.5	12	0.06			
17	38	34.56	10	25	15	11.5	12	0.07			
18	40	36.57	10	25	15	11.5	12	0.07			
19	42	38.58	10	28	15	11.5	16	0.08			
20	44	40.59	10	28	15	11.5	16	0.08			
21	46	42.61	10	28	15	11.5	16	0.09			
22	48	44.62	10	30	15	11.5	16	0.10			
23	50	46.63	10	30	15	11.5	16	0.11			
24	52	48.65	10	30	15	11.5	16	0.12			
25	54	50.66	10	35	15	11.5	20	0.14			
26	56	52.68	10	35	15	11.5	20	0.14			
27	58	54.70	10	35	15	11.5	20	0.15			
28	60	56.71	10	35	15	11.5	20	0.15			
29	62	58.73	10	35	15	11.5	20	0.16			
30	64	60.75	10	35	15	11.5	20	0.16			
31	66	62.77	10	40	40	12.5	22	0.20			
32	68	64.78	10	40	40	12.5	22	0.20			
33	70	66.80	10	40	40	12.5	22	0.20			
34	72	68.82	10	40	40	12.5	22	0.21			
35	74	70.84	10	40	40	12.5	22	0.21			
36	76	72.86	10	40	40	12.5	22	0.22			
37	78	74.88	10	40	40	12.5	22	0.26			
38	80	76.90	10	40	40	12.5	22	0.26			
39	82	78.91	10	40	40	12.5	22	0.27			
40	84	80.93	10	40	40	12.5	22	0.27			
41	87	82.95	12	50	50	12.5	30	0.32			
42	89	84.97	12	50	50	12.5	30	0.32			
43	91	86.99	12	50	50	12.5	30	0.40			
44	93	89.01	12	50	50	12.5	30	0.41			
45	95	91.03	12	50	50	12.5	30	0.41			
48	101	97.09	12	50	50	12.5	30	0.43			
50	105	101.13	12	50	50	12.5	30	0.46			
54	113	109.21	12	50	50	12.5	30	0.47			
60	125	121.33	12	50	50	12.5	30	0.52			
65	135	131.43	12	50	50	13.5	30	0.72			
70	145	141.54	12	50	50	13.5	30	0.77			

STANDARD SPROCKET

TYC 35 = (3/8" Pitch)

PITCH 9.525 mm

Teeth	groove width	measure Diam
9	4.40	17
10		20
11		23
12		26
13		29

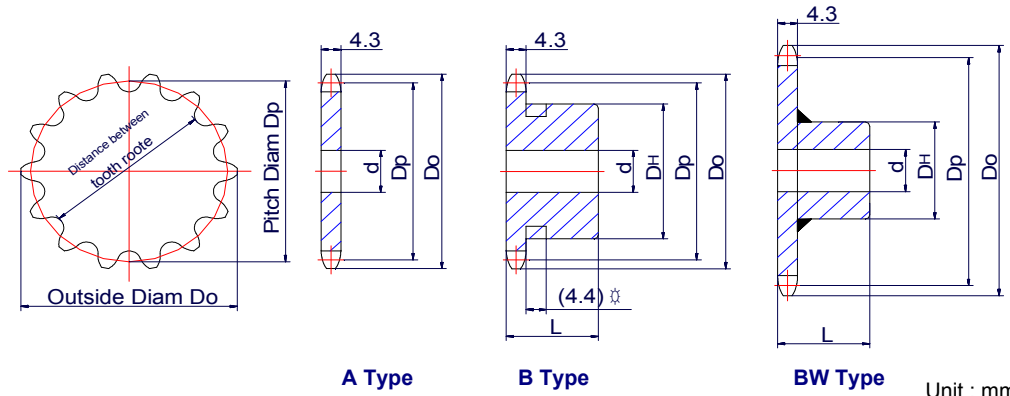

A Type

B Type

BW Type

Unit : mm

No. of Teeth	Outside Dia. (Do)	Pitch Dia. (Dp)	Type "A"			Type "B" SINGLE STRAND						
			Stock Bore (d)	Approx Mass. (kg)	Material	HUB			BORE (d)		Approx Mass. (kg)	Material
						Stock Bore	Diam. (Dh)	Length (L)	Min.	Max.		
9	31	27.85			SS41	8	* 21.5	20	10.5	11	0.06	S45C
10	35	30.82	9	0.02		8	* 24.5	20	10.5	12	0.08	
11	38	33.81	9	0.03		10	* 27	20	10.5	14	0.09	
12	41	36.80	9	0.03		10	* 30.5	20	11.5	16	0.12	
13	44	39.80	9	0.04		10	* 32	20	11.5	18	0.12	
14	47	42.80	9	0.04		10	32	20	11.5	18	0.12	
15	51	45.81	9	0.05		10	35	20	11.5	20	0.16	
16	54	48.82	9	0.05		10	37	20	11.5	20	0.19	
17	57	51.84	9	0.07		12	41	20	13.5	25	0.22	
18	60	54.85	11	0.07		12	44	20	13.5	25	0.25	
19	63	57.87	11	0.09		12	47	20	13.5	28	0.28	
20	66	60.89	11	0.09		12	50	20	13.5	30	0.32	
21	69	63.91	11	0.11		12	53	20	13.5	32	0.36	
22	72	66.93	11	0.11		12	56	20	13.5	35	0.37	
23	75	69.95	11	0.11		12	60	20	13.5	38	0.38	
24	78	72.97	11	0.14		12	53	22	13.5	32	0.43	
25	81	76.00	11	0.16		12	53	22	13.5	32	0.44	
26	84	79.02	11	0.16		12	53	22	13.5	32	0.45	
27	87	82.05	11	0.17		12	53	22	13.5	32	0.46	
28	90	85.07	11	0.18		12	53	22	13.5	32	0.48	
29	93	88.10	11			12	53	22	13.5	32	0.49	
30	96	91.12	11	0.23		12	53	22	13.5	32	0.51	
31	99	94.15	11			12	53	22	13.5	32	0.53	
32	102	97.18	11	0.27		12	53	22	13.5	32	0.54	
33	105	100.20	11	0.28		12	53	22	13.5	32	0.56	
34	109	103.23	11	0.29		12	53	22	13.5	32	0.57	
35	112	106.26	11	0.30		12	53	22	13.5	32	0.59	
36	115	109.29	11	0.32		12	53	22	14.5	32	0.61	
37	118	112.32	12			12	63	25	14.5	42	0.68	
38	121	115.34	12	0.41		12	63	25	14.5	42	0.82	
39	124	118.37	12			12	63	25	14.5	42	0.84	
40	127	121.40	12	0.43		12	63	25	14.5	42	0.85	
41	130	124.43	12			16	63	25	18	42	0.91	
42	133	127.46	12	0.43		16	63	25	18	42	0.93	
43	136	130.49	16			16	63	25	18	42	0.95	
44	139	133.52	16			16	63	25	18	42	0.97	
45	142	136.55	16	0.49		16	63	25	18	42	1.00	
46	145	139.58	16	0.51		16	63	25	18	42	1.01	
47	148	142.61	16			16	63	25	18	42	1.03	
48	151	145.64	16	0.55		16	63	25	18	42	1.05	
50	157	151.70	16	0.60		16	63	25	18	42	1.07	
53	166	160.79	16			16	63	25	18	42	1.09	
54	169	163.82	16	0.70		16	63	25	18	42	1.10	
55	172	166.85	16	0.71		16	63	25	18	42	1.25	
60	187	182.00	16	0.80		16	63	25	18	42	1.30	
64	200	194.12	16			16	63	25	18	42	1.46	
65	203	197.15	16			16	68	25	18	42	1.67	
70	218	212.30	16			16	68	25	18	42	1.80	

- Note:
1. Determine the required bore size less than the Max. value shown above taking strength reduction into consideration.
 2. The shaded area of the above table indicates heat treated teeth.
 3. Those marked * have slot on hub.

STANDARD SPROCKET

TYC 40 = (1/2" Pitch)

PITCH 12.70 mm

C = 14.4

Teeth	groove width	measure Diam
9	5.20	23
10		27
11		31
12		35

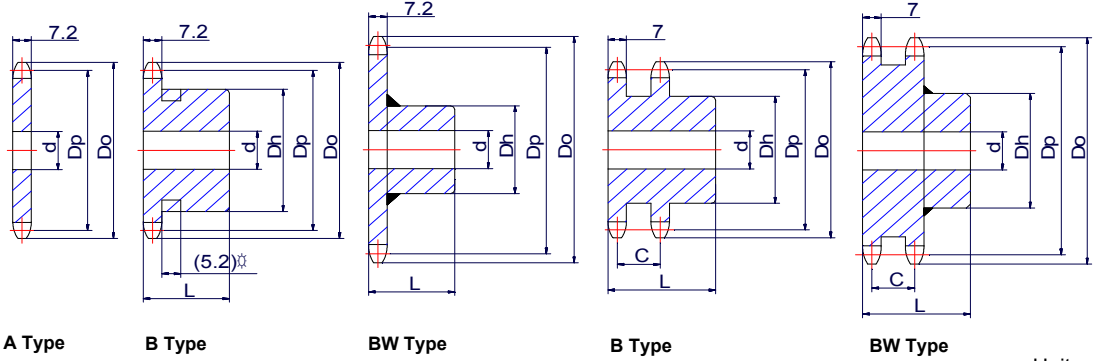

Unit : mm

No. of Teeth	Outside Dia. (Do)	Pitch Dia. (Dp)	Type "A"			Type "B" SINGLE STRAND						Type "B" DOUBLE STRAND							
			Stock Bore (d)	Approx. Mass. (kg)	Material	HUB			BORE (d)		Approx. Mass. (kg)	Material	HUB			BORE (d)		Approx. Mass. (kg)	Material
						Stock Bore	Diam. (Dh)	Length (L)	Min.	Max.			Stock Bore	Diam. (Dh)	Length (L)	Min.	Max.		
9	43	37.13	10			9	* 28	22	10.5	16	0.11								
10	47	41.10	10	0.05		9	* 32	22	11.5	18	0.14								
11	51	45.08	12	0.09		10	* 36	22	12.5	20	0.19								
12	55	49.07	14	0.10		12	* 40	22	12.5	22	0.22								
13	59	53.07	14	0.12		14	37	22	15.5	20	0.23								
14	63	57.07	14	0.14		14	42	22	15.5	25	0.28								
15	67	61.08	14	0.16		14	46	22	15.5	28	0.34								
16	71	65.10	14	0.18		14	50	22	15.5	30	0.40								
17	76	69.12	14	0.20		14	54	22	15.5	32	0.46								
18	80	73.14	14	0.23		14	57	22	15.5	35	0.51								
19	84	77.16	14	0.24		14	62	25	15.5	40	0.59								
20	88	81.18	14	0.29		14	67	25	16.5	45	0.76								
21	92	85.21	14	0.30		14	71	25	16.5	48	0.85								
22	96	89.24	14	0.35		14	75	25	16.5	51	0.95								
23	100	93.27	14	0.38		14	77	25	16.5	51	1.00								
24	104	97.30	14	0.40		14	63	25	16.5	42	0.84								
25	108	101.33	14	0.45		14	63	25	16.5	42	0.88								
26	112	105.36	14	0.49		14	63	25	16.5	42	0.92								
27	116	109.40	14	0.50		14	63	25	16.5	42	0.96								
28	120	113.43	14	0.56		14	63	25	16.5	42	1.00								
29	124	117.46	14	0.60		14	63	25	16.5	42	1.00								
30	128	121.50	14	0.63		14	63	25	16.5	42	1.10								
31	133	125.53	14	0.65		14	68	28	16.5	45	1.20								
32	137	129.57	14	0.70		14	68	28	16.5	45	1.30								
33	141	133.61	14	0.75		14	68	28	16.5	45	1.30								
34	145	137.64	14	0.80		14	68	28	16.5	45	1.30								
35	149	141.68	14	0.85		14	68	28	16.5	45	1.40								
36	153	145.72	16	0.90		16	68	28	18	45	1.50								
38	161	153.79	16	1.00		16	68	28	18	45	1.60								
39	165	157.83	16	1.15		16	68	28	18	45	1.65								
40	169	161.87	16	1.20		16	68	28	18	45	1.70								
41	173	165.91	16	1.22		16	73	32	18	48	2.00								
42	177	169.95	16	1.25		16	73	32	18	48	2.05								
43	181	173.98	16	1.30		16	73	32	18	48	2.10								
44	185	178.02	16	1.35		16	73	32	18	48	2.17								
45	189	182.06	16	1.40		16	73	32	18	48	2.25								
48	201	194.18	16	1.63		16	73	32	18	48	2.45								
49	205	198.22	16	1.73		16	73	32	18	48	2.51								
50	209	202.26	16	1.80		16	73	32	18	48	2.60								
51	214	206.30	16	1.88		16	73	32	18	48	2.65								
52	218	210.34	16	1.93		16	73	32	18	48	2.72								
53	222	214.38	16	1.98		16	73	32	18	48	2.80								
54	226	218.42	16	2.00		16	73	32	18	48	2.90								
60	250	242.66	16	2.60		16	73	32	18	48	3.40								
65	270	262.87	16	3.00		16	83	35	18	55	4.10								
70	290	283.07	20	3.50		20	83	35	18	55	4.57								
72	298	291.16	20	3.70		20	83	35	22	55	4.80								
75	311	303.28	20	4.00		20	83	35	22	55	5.10								

- Note:
- Determine the required bore size less than the Max. value shown above taking strength reduction into consideration.
 - The shaded area of the above table indicates heat treated teeth.
 - Due to material availability and production reasons, forged S45C may be used for teeth portion and SS41 for hub and welded for double sprockets with 31 ~ 40 teeth without notice.
 - Those marked * have slot on hub.

STANDARD SPROCKET

TYC 50 = (5/8" Pitch)

PITCH 15.875 mm

C = 18.1

Teeth	groove width	measure Diam
8	6.40	22
9		29
10		34
11		39
12		44
13		49

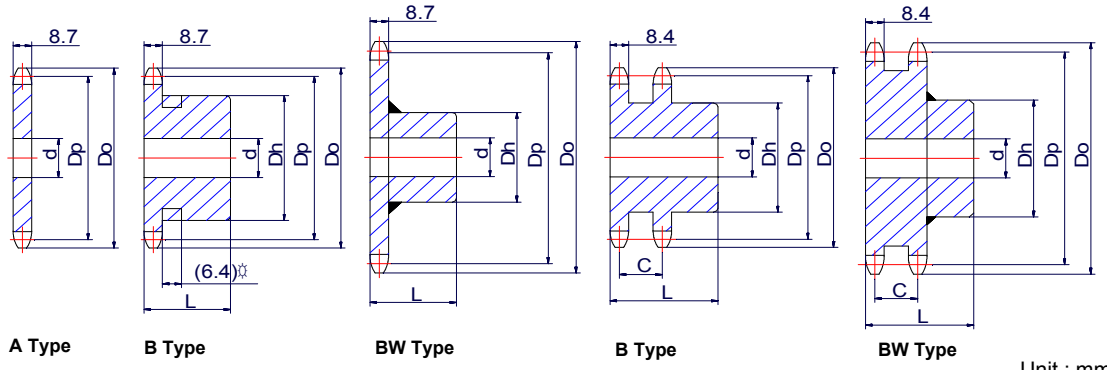

Unit : mm

No. of Teeth	Outside Dia. (Do)	Pitch Dia. (Dp)	Type "A"			Type "B" SINGLE STRAND						Type "B" DOUBLE STRAND							
			Stock Bore (d)	Approx. Mass. (kg)	Material	HUB			BORE (d)		Approx. Mass. (kg)	Material	HUB			BORE (d)		Approx. Mass. (kg)	Material
						Stock Bore	Diam. (Dh)	Length (L)	Min.	Max.			Stock Bore	Diam. (Dh)	Length (L)	Min.	Max.		
9	53	46.42				12	* 34	25	13.5	18	0.20								
10	58	51.37	14	0.14	SS41	12	* 40	25	16.5	22	0.27	S45C	14	35	40	16	20	0.50	S45C
11	64	56.35	14	0.17		14	* 45.5	25	16.5	28	0.33		14	40	40	16	22	0.50	
12	69	61.34	14	0.20		14	* 50	25	16.5	30	0.41		14	42	40	16	25	0.62	
13	74	66.34	14	0.23		14	* 51	25	16.5	32	0.46		14	49	40	16	30	0.75	
14	79	71.34	14	0.27		14	52	25	16.5	32	0.52		14	54	40	16	32	0.90	
15	84	76.35	14	0.30		14	57	25	16.5	35	0.62		14	59	40	16	38	1.10	
16	89	81.37	14	0.35		14	62	25	16.5	40	0.72		14	64	45	16	42	1.40	
17	94	86.39	14	0.40		14	67	25	16.5	45	0.83		14	68	45	20	45	1.60	
18	100	91.42	14	0.45		14	72	28	16.5	48	1.00		14	74	45	20	48	1.80	
19	105	96.45	14	0.48		14	73	28	16.5	48	1.10		14	79	45	20	55	2.10	
20	110	101.48	14	0.50		14	73	28	16.5	48	1.20		18	84	45	20	57	2.30	
21	115	106.51	14	0.60		14	73	28	16.5	48	1.20		18	89	45	20	60	2.60	
22	120	111.55	14	0.66		14	73	28	16.5	48	1.30		18	94	50	20	63	3.00	
23	125	116.59	16	0.72		16	73	28	18	48	1.30		18	99	50	20	66	3.50	
24	130	121.62	16	0.78		16	73	28	18	48	1.40		18	105	50	20	70	3.80	
25	135	126.66	16	0.85		16	73	28	18	48	1.50		18	105	50	20	70	4.20	
26	140	131.70	16	0.90		16	73	28	18	48	1.50		18	105	50	20	70	4.50	
27	145	136.74	16	1.00		16	73	28	18	48	1.50		18	105	50	20	70	4.80	
28	150	141.79	16	1.05	16	73	28	18	48	1.60	18	110	50	20	75	5.10			
29	155	146.83	16	1.12	16	73	28	18	48	1.60	18	110	50	20	75	5.50			
30	161	151.87	16	1.20	16	73	28	18	48	1.70	18	120	50	20	80	5.80			
31	166	156.92	16	1.30	16	73	28	18	48	1.80	24	120	50	25	80	5.90			
32	171	161.96	16	1.35	16	73	28	18	48	1.80	24	120	50	25	80	6.00			
33	176	167.01	16	1.45	16	73	28	18	48	1.90	24	120	50	25	80	6.50			
34	181	172.05	16	1.55	16	73	28	18	48	2.10	24	120	50	25	80	6.80			
35	186	177.10	16	1.65	16	73	28	18	48	2.20	24	117	50	25	80	7.00			
36	191	182.15	16	1.75	16	83	35	18	55	2.85	24	117	50	25	80	7.00			
37	196	187.19	16	1.85	16	83	35	18	55	2.95	24	117	50	25	80				
38	201	192.24	16	1.95	16	83	35	18	55	3.05	24	117	50	25	80	8.00			
39	206	197.29	16	2.05	16	83	35	18	55	3.15	24	117	50	25	80				
40	211	202.33	16	2.15	16	83	35	18	55	3.25	24	117	56	25	80	9.00			
41	216	207.38	16	2.25	16	83	35	18	55	3.40	24	117	56	25	80				
42	221	212.43	16	2.40	16	83	35	18	55	3.50	24	98	56	25	66	7.00			
44	231	222.53	16	2.60	16	83	35	18	55	3.70	24	98	56	25	66				
45	237	227.58	16	2.70	16	83	35	18	55	3.85	24	98	56	25	66	7.30			
48	252	242.73	16	3.10	16	83	35	18	55	4.20	24	98	56	25	66	8.00			
50	262	252.83	16	3.40	16	83	35	18	55	4.50	24	98	56	25	66	9.00			
54	282	273.03	16	3.95	16	83	35	18	55	5.05	24	98	56	25	66	9.90			
60	312	303.33	16	4.90	16	83	35	18	55	6.00	24	98	56	25	66	11.70			
64	333	323.53	20	5.60	20	93	40	22	63		24	98	63	25	66				
65	338	328.58	20	5.75	20	93	40	22	63	7.40	24	98	63	25	66	13.00			
68	353	343.74	20	6.32	20	93	40	22	63	7.94	24	98	63	25	66				
70	363	353.84	20	6.70	20	93	40	22	63	8.30	24	98	63	25	66				
72	373	363.94	20	7.05	20	93	40	22	63		24	98	63	25	66	15.00			
75	388	379.10	20	7.70	20	93	40	22	63	9.35									

Note:

- Determine the required bore size less than the Max. value shown above taking strength reduction into consideration.
- The shaded area of the above table indicates heat treated teeth.
- Due to material availability and production reasons, forget S45C may be used for teeth portion and SS41 for hub and welded for double sprockets with 26 ~ 31 teeth without notice.
- Those marked * have slot on hub.

STANDARD SPROCKET

TYC 60 = (3/4" Pitch)

PITCH 19.05 mm

C = 22.8

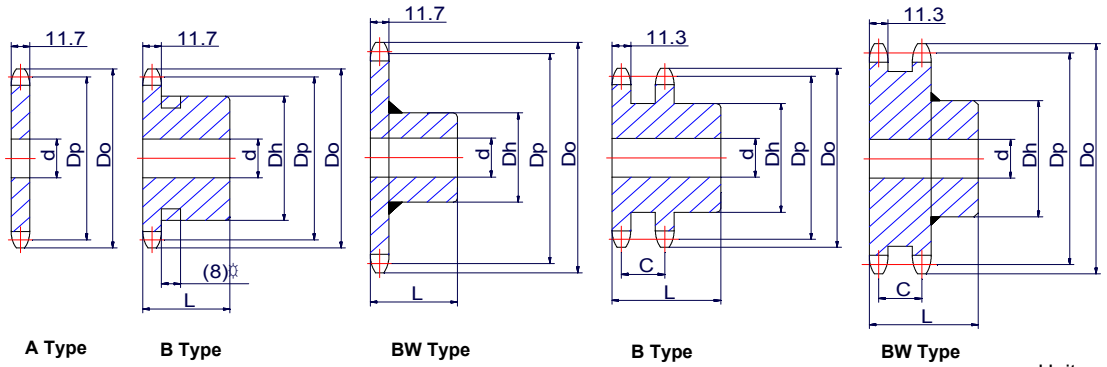

Teeth	groove width	measure Diam
8	8.00	26
9		32
10		37
11		45

Unit : mm

No. of Teeth	Outside Dia. (Do)	Pitch Dia. (Dp)	Type "A"			Type "B" SINGLE STRAND						Type "B" DOUBLE STRAND							
			Stock Bore (d)	Approx. Mass. (kg)	Material	HUB			BORE (d)		Approx. Mass. (kg)	Material	HUB			BORE (d)		Approx. Mass. (kg)	Material
						Stock Bore	Diam. (Dh)	Length (L)	Min.	Max.			Stock Bore	Diam. (Dh)	Length (L)	Min.	Max.		
9	64	55.70	12			12	* 43	32	13.5	25	0.40		16	32	50	18	20		
10	70	61.65	14	0.27		14	* 49	32	16.5	30	0.49		16	28	50	18	20	0.90	
11	76	67.62	14	0.30		14	* 51	32	16.5	32	0.60		16	44	50	18	25	1.00	
12	83	73.60	14	0.38		14	51	32	16.5	32	0.69		16	50	50	18	30	1.20	
13	89	79.60	14	0.45		14	57	32	16.5	35	0.81		18	57	50	20	38	1.40	
14	95	85.61	16	0.50		16	62	32	18	40	0.96		18	64	56	20	45	1.80	
15	101	91.63	16	0.60		16	68	32	18	45	1.10		18	70	56	20	48	2.10	
16	107	97.65	16	0.65		16	73	32	18	48	1.30		18	76	56	20	51	2.50	
17	113	103.67	16	0.75		16	73	32	18	48	1.40		18	82	56	20	55	2.60	
18	119	109.70	16	0.84		16	83	40	18	55	2.00		18	88	56	20	60	3.20	
19	126	115.74	16	0.93		16	83	40	18	55	2.10		18	94	56	20	63	3.70	
20	132	121.78	16	1.05		16	83	40	18	55	2.10		24	100	56	25	66	4.20	
21	138	127.82	16	1.15		16	83	40	18	55	2.30		24	100	56	25	66	4.40	
22	144	133.86	16	1.25		16	83	40	18	55	2.50		24	100	56	25	66	4.90	
23	150	139.90	16	1.40		16	83	40	18	55	2.50		24	100	56	25	66	4.70	
24	156	145.95	16	1.50		16	83	40	18	55	2.60		24	120	56	25	80	6.00	
25	162	151.99	16	1.62		16	83	40	18	55	2.70		24	120	56	25	80	6.40	
26	168	158.04	16	1.78		16	83	40	18	55	2.90		24	120	56	25	80	6.80	
27	174	164.09	20	1.90		20	83	40	22	55	3.00		24	120	56	25	80	7.30	
28	181	170.14	20	2.05		20	83	40	22	55	3.10		24	120	56	25	80	7.80	
29	187	176.19	20	2.20		20	83	40	22	55	3.30		28	120	56	30	80	8.20	
30	193	182.25	20	2.35		20	83	40	22	55	3.40		28	120	56	30	89	9.00	
31	199	188.30	20	2.50		20	83	40	22	55	3.64		28	127	56	30	89	9.30	
32	205	194.35	20	2.68		20	83	40	22	55	3.80		28	127	56	30	89	9.50	
33	211	200.41	20	2.85		20	83	40	22	55	4.00		28	127	56	30	89	9.70	
34	217	206.46	20	3.02		20	83	40	22	55	4.15		28	127	56	30	89	10.50	
35	223	212.52	20	3.02		20	83	40	22	55	4.33		28	127	56	30	89	11.00	
36	229	218.57	20	3.40		20	83	40	22	55	4.52		28	98	56	30	66	8.50	
37	235	224.63	20	3.60		20	83	40	22	55	4.70		28	98	56	30	66		
38	241	230.69	20	3.80		20	83	40	22	55	4.90		28	98	56	30	66	9.00	
39	247	236.74	20	4.00		20	83	40	22	55	5.10		28	98	56	30	66		
40	253	242.80	20	4.20		20	83	40	22	55	5.30		28	98	56	30	66	9.70	
42	266	254.92	20	4.63		20	93	45	22	63	6.40		28	107	56	30	75	11.00	
43	272	260.98	20	4.85		20	93	45	22	63	6.60		28	107	56	30	75		
44	278	267.03	20	5.10		20	93	45	22	63	6.88		28	107	56	30	75		
45	284	273.09	20	5.30		20	93	45	22	63	7.10		28	107	71	30	75	12.80	
48	302	291.27	20	6.10		20	93	45	22	63	7.85		28	107	71	30	75	14.00	
60	375	363.99	20	9.50		20	93	45	22	63	11.30		28	107	71	30	75	21.50	
64	399	388.24	20			20	93	45	22	63	12.50		28	107	71	30	75		
65	405	394.30	26	11.20		26	107	45	28	75	13.50		28	107	71	30	75	24.00	
70	436	424.61	26	13.00		26	107	45	28	75	15.30		28	107	71	30	75	30.00	
72	448	436.73	26	13.70		26	107	45	28	75									
75	466	454.92	26	14.90		26	107	45	28	75	17.20								

Note:

1. Determine the required bore size less than the Max. value shown above taking strength reduction into consideration.
2. The shaded area of the above table indicates heat treated teeth.
3. Due to material availability and production reasons, forget S45C may be used for teeth portion and SS41 for hub and welded for double sprockets with 23 ~ 35 teeth without notice.
4. Those marked * have slot on hub.

STANDARD SPROCKET

TYC 80 = (1" Pitch)

PITCH 25.4 mm

C = 29.3

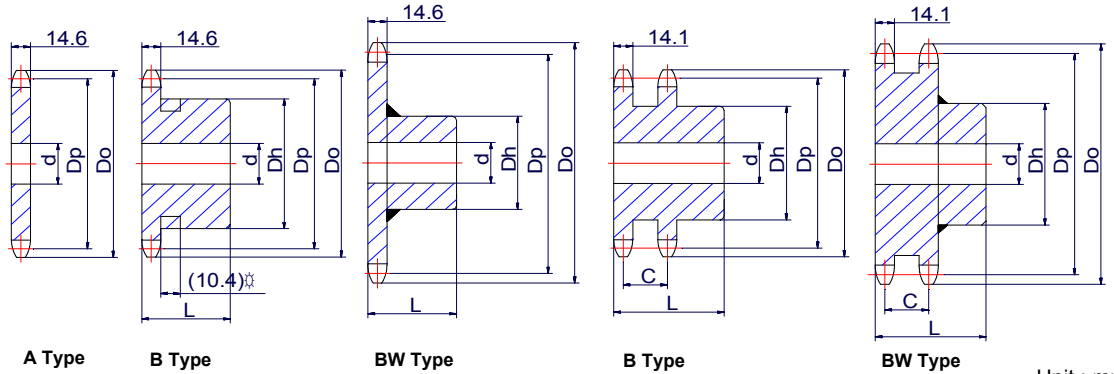

Teeth	groove	measure
	width	Diam
9	10.40	44

Unit : mm

No. of Teeth	Outside Dia. (Do)	Pitch Dia. (Dp)	Type "A"			Type "B" SINGLE STRAND							Type "B" DOUBLE STRAND						
			Stock Bore (d)	Approx. Mass. (kg)	Material	HUB			BORE (d)		Approx. Mass. (kg)	Material	HUB			BORE (d)		Approx. Mass. (kg)	Material
						Stock Bore	Diam. (Dh)	Length (L)	Min.	Max.			Stock Bore	Diam. (Dh)	Length (L)	Min.	Max.		
9	85	74.26	16			16	* 57	40	18.5	35	0.87		20	48	63	23	35	2.00	
10	93	82.20	16	0.60		16	52	40	18.5	32	1.02		20	56	63	23	38	2.50	
11	102	90.16	16	0.73		16	60	40	18.5	38	1.25		22	60	63	25	46	2.70	
12	110	98.14	16	0.85		16	67	40	18	48	1.60		22	69	63	25	55	3.40	
13	118	106.14	16	1.00		16	77	40	18	51	1.90		22	88	63	25	60	3.90	
14	127	114.15	16	1.16		20	93	40	22	63	2.30		22	95	63	25	63	4.40	
15	135	122.17	20	1.30		20	93	40	22	63	2.50		22	100	71	25	66	5.40	
16	143	130.20	20	1.50		20	93	40	22	63	2.95		22	100	71	25	66	6.00	
17	151	138.23	20	1.70		20	93	40	22	63	3.15		22	120	71	25	80	7.50	
18	159	146.27	20	1.90		20	93	40	22	63	3.40		22	120	71	25	80	8.00	
19	167	154.32	20	2.10		20	93	40	22	63	3.60		22	130	71	25	89	9.00	
20	176	162.37	20	2.35		20	93	40	22	63	3.85		22	130	71	25	89	9.50	
21	184	170.42	20	2.57		26	107	45	28	75	5.00		30	117	71	35	80	8.80	
22	192	178.48	26	2.82		26	107	45	28	75	5.23		30	117	71	35	80	9.30	
23	200	186.54	26	3.10		26	107	45	28	75	5.50		30	117	80	35	80	10.50	
24	208	194.60	26	3.35		26	107	45	28	75	5.80		30	117	80	35	80	11.10	
25	216	202.66	26	3.65		26	107	45	28	75	6.10		30	117	80	35	80	11.70	
26	224	210.72	26	3.95		26	107	45	28	75	6.40		30	117	80	35	80		
27	233	218.79	26	4.25		26	107	45	28	75	6.75		30	117	80	35	80		
28	241	226.86	26	4.60		26	107	45	28	75	7.10		30	117	80	35	80		
29	249	234.93	26	4.93		26	107	45	28	75	7.40		30	117	80	35	80		
30	257	243.00	26	5.30		26	107	45	28	75	7.80		30	117	80	35	80		
31	265	251.07	26	5.63		26	107	45	28	75	8.15		30	117	80	35	80		
32	273	259.14	26	6.00		26	107	45	28	75	8.50		30	117	80	35	80		
33	281	267.21	26	6.40		26	107	45	28	75	8.90		30	117	80	35	80		
34	289	275.28	26	6.80		26	107	45	28	75	9.30		30	117	80	35	80		
35	297	283.36	26	7.20		26	117	50	28	80	10.60		30	117	80	35	80		
36	306	291.43	26	7.60		26	117	50	28	80	11.00		30	117	80	35	80		
37	314	299.51	26	8.00		26	117	50	28	80	11.40		30	117	80	35	80		
38	322	307.58	26	8.50		26	117	50	28	80	11.90		38	127	80	40	89		
39	330	315.66	26	8.90		26	117	50	28	80	12.40		38	127	90	40	89		
40	338	323.74	26	9.40		26	117	50	28	80	12.80		38	127	90	40	89		
41	346	331.81	26	9.90		26	117	50	28	80	13.30		38	127	90	40	89		
42	354	339.89	26	10.30		26	117	50	28	80	13.80		38	127	90	40	89		
43	362	347.97	26	10.80		26	117	50	28	80	14.30		38	127	90	40	89		
44	370	356.05	26	11.40		26	117	50	28	80	14.90		38	127	90	40	89		
45	378	364.12	26	11.90		26	117	50	28	80	15.80		38	127	90	40	89		
48	403	388.36	26	13.50		26	117	50	28	80	20.00		38	127	90	40	89		
49	411	396.44	26	14.08		26	117	50	28	80	23.10		38	127	90	40	89		
54	451	436.84	26	17.10		26	117	50	28	80	24.80		38	127	90	40	89		
60	500	485.33	26	21.10		26	117	50	28	80	25.58		38	127	90	40	89		
64	532	517.65	26	24.05		26	127	63	28	89	28.80		38	127	90	40	89		
65	540	525.73	26	24.80		26	127	63	28	89	32.10		38	127	90	40	89		
66	548	533.82	26	25.58		26	127	63	28	89	36.20		38	127	90	40	89		
70	581	566.15	26	28.80		26	127	63	28	89			38	127	90	40	89		
75	621	606.56	26	33.10		26	127	63	28	89			38	127	90	40	89		

Note:

- Determine the required bore size less than the Max. value shown above taking strength reduction into consideration.
- The shaded area of the above table indicates heat treated teeth.
- Those marked * have slot on hub.

STANDARD SPROCKET

TYC 100 = (1-1/4" Pitch)

PITCH 31.75 mm

C = 35.8

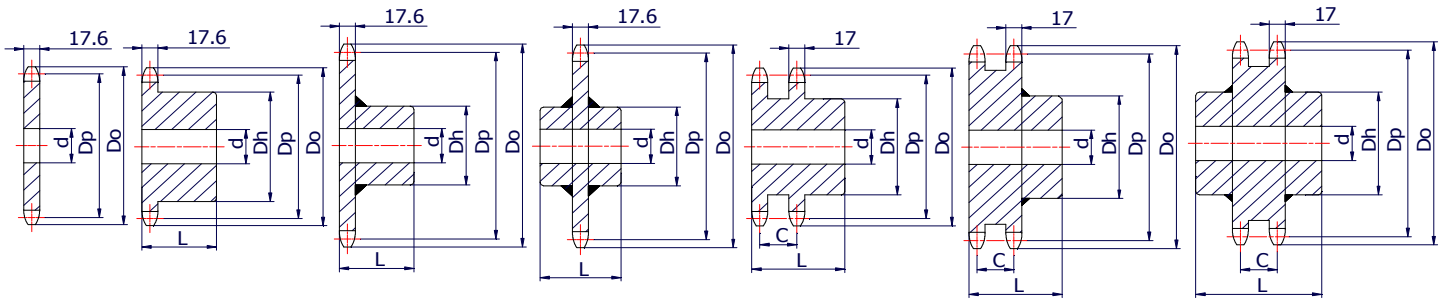

A Type B Type BW Type CW Type B Type BW Type CW Type Unit : mm

No. of Teeth	Outside Dia. (Do)	Pitch Dia. (Dp)	Type "A"			Type "B" SINGLE STRAND						Type "B" DOUBLE STRAND							
			Stock Bore (d)	Approx. Mass. (kg)	Material	HUB			BORE (d)		Approx. Mass. (kg)	Material	HUB			BORE (d)		Approx. Mass. (kg)	Material
						Stock Bore	Diam. (Dh)	Length (L)	(d)				Stock Bore	Diam. (Dh)	Length (L)	(d)			
									Min.	Max.						Min.	Max.		
9	106	92.83	20	9.80	SS41	20	70	50	22	40	1.60	S45C	22	70	80	24	46	3.50	S45C
10	117	102.75	20	1.10		20	65	50	22	45	1.90		22	80	80	24	55	4.20	
11	127	112.70	20	1.30		20	75	50	22	51	2.30		26	90	80	30	60	5.00	
12	138	122.67	20	1.60		20	86	50	22	57	2.90		26	100	80	30	66	6.00	
13	148	132.67	20	1.90		20	94	50	22	63	3.10		26	110	80	30	75	7.00	
14	158	142.68	20	2.15		20	98	50	22	66	3.60		26	120	80	30	80	7.10	
15	168	152.71	20	2.50		20	98	50	22	66	4.20		26	130	80	30	89	7.70	
16	179	162.75	20	2.83		20	98	50	22	66	4.60		26	130	80	30	89	7.90	
17	189	172.79	20	3.20		20	107	50	22	75	5.30		26	130	80	30	89	8.90	
18	199	182.84	20	3.60		20	107	50	22	75	5.70		26	130	80	30	89	9.60	
19	209	192.90	20	4.00		20	107	50	22	75	6.10		26	130	90	30	89	12.80	
20	220	202.96	20	4.40		20	107	50	22	75	6.50		26	130	90	30	89	13.50	
21	230	213.03	20	4.90		20	107	50	22	75	7.00		26	130	90	30	89	14.30	
22	240	223.10	20	5.35		20	117	56	22	80	7.90		26	127	90	30	89	15.50	
23	250	233.17	20	5.80		20	117	56	22	80	8.50		26	127	90	30	89	16.60	
24	260	243.25	20	6.40		20	117	56	22	80	8.80		30	137	90	40	95	17.80	
25	270	253.32	20	6.90		20	117	56	22	80	9.30		30	137	90	40	95	18.50	
26	281	263.41	20	7.50		20	117	56	22	80	9.80		30	137	90	40	95	19.80	
27	291	273.49	20	8.10		20	117	56	22	80	10.30		30	137	90	40	95	22.00	
28	301	283.57	20	8.70		20	117	56	22	80	10.90		30	137	90	40	95	24.30	
29	311	293.66	20	9.30		26	117	56	28	80	11.50		30	137	90	40	95	27.00	
30	321	303.75	26	10.00		26	117	56	28	80	12.10		30	137	90	40	95	30.90	
31	331	313.83	26	10.65		26	117	56	28	80	13.40		30	137	90	40	95	32.50	
32	341	323.92	26	11.35		26	117	56	28	80	14.50		30	137	90	40	95	36.00	
33	352	334.01	26	12.00		26	117	56	28	80	16.10		30	137	90	40	95	40.70	
34	362	344.11	26	12.80		26	117	56	28	80	16.60		30	137	90	40	95	45.00	
35	372	354.20	26	13.50		26	127	63	28	89	17.50		30	147	100	40	103	49.30	
36	382	364.29	26	14.40		26	127	63	28	89	18.00		30	147	100	40	103	53.00	
37	392	374.38	26	15.10		26	127	63	28	89	18.90		30	147	100	40	103	58.00	
38	402	384.48	26	16.00		26	127	63	28	89	20.40		30	147	100	40	103	63.00	
39	412	394.57	26	16.80		26	127	63	28	89	21.50		30	147	100	40	103	68.30	
40	422	404.67	26	17.70		26	127	63	28	89	22.60		30	147	100	40	103		
41	433	414.77	26	18.60		26	127	63	28	89	24.70		30	147	100	40	103		
42	443	424.86	26	19.50	26	127	63	28	89	36.70	30	147	100	40	103				
43	453	434.96	26	20.50	26	127	63	28	89	27.50	30	147	100	40	103				
44	463	445.06	26	21.45	26	127	63	28	89	30.00	30	147	100	40	103				
45	473	455.16	26	22.40	26	127	63	28	89	37.40	30	147	100	40	103				
46	483	465.25	26	23.40	26	127	63	28	89	41.60	30	147	100	40	103				
47	493	475.35	26		26	127	63	28	89	44.30	30	147	125	40	103				
48	503	485.45	26	25.50	26	127	63	28	89	44.50									
50	524	505.65	26	27.70	26	127	63	28	89	44.70									
52	544	525.85	26	29.90	26	127	63	28	89	47.00									
54	564	546.05	26	32.30	26	147	80	28	103										
55	574	556.15	26		26	147	80	28	103										
60	625	606.66	26	39.90	26	147	80	28	103										
65	675	657.17	26	46.80	26	147	80	28	103										
70	726	707.68	26	54.30	26	147	100	28	103										
75	777	758.20	26	62.30	26	147	100	28	103										

Note:

- Determine the required bore size less than the Max. value shown above taking strength reduction into consideration.
- The shaded area of the above table indicates heat treated teeth.

STANDARD SPROCKET

TYC 120 = (1-1/2" Pitch)

PITCH 38.1 mm

C = 45.4

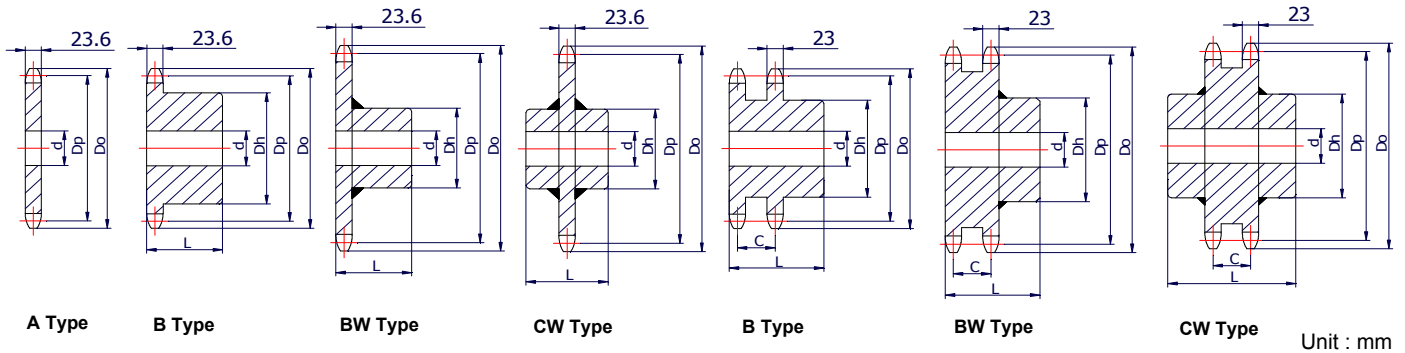

No. of Teeth	Outside Dia. (Do)	Pitch Dia. (Dp)	Type "A"			Type "B" SINGLE STRAND						Type "B" DOUBLE STRAND							
			Stock Bore (d)	Approx. Mass. (kg)	Material	HUB			BORE (d)		Approx. Mass. (kg)	Material	HUB			BORE (d)		Approx. Mass. (kg)	Material
						Stock Bore	Diam. (Dh)	Length (L)					Stock Bore	Diam. (Dh)	Length (L)				
									Min.	Max.						Min.	Max.		
9	128	111.40	20	2.16	SS41	20	66	56	22	56	2.70	S45C	26	68	100	28	55	8.00	S45C
10	140	123.29	20	2.60		20	78	56	22	51	3.20		26	80	100	28	60	8.70	
11	153	135.23	20	3.10		20	91	56	22	60	4.00		28	100	100	30	66	9.20	
12	165	147.21	20	3.60		20	98	56	22	66	4.80		28	115	100	30	75	10.90	
13	177	159.20	20	4.20		20	107	56	22	75	6.36		28	120	100	30	80	11.40	
14	190	171.22	20	4.80		20	117	63	22	80	7.80		38	120	100	40	80	13.20	
15	202	183.25	20	5.50		20	117	63	22	80	8.40		38	140	100	40	95	16.50	
16	214	195.29	20	6.20		20	117	63	22	80	9.10		38	140	100	40	95	19.00	
17	227	207.35	20	6.95		20	117	63	22	80	9.90		38	150	100	40	103	21.00	
18	239	219.41	20	7.70		20	117	63	22	80	10.70		38	150	100	40	103	23.00	
19	251	231.48	20	8.55		20	127	63	22	89	12.10		38	150	100	40	103	26.00	
20	263	243.55	20	9.40		20	127	63	22	89	13.00		38	150	100	40	103	28.00	
21	276	255.63	26	10.30		26	127	63	28	89	13.40		38	150	100	40	103	30.00	
22	288	267.72	26	11.30		26	127	63	28	89	14.50		38	150	100	40	103	33.00	
23	300	279.80	26	12.30		26	127	63	28	89	15.20		38	157	100	40	103	31.00	
24	312	291.90	26	13.30		26	127	63	28	89	16.20		38	157	100	40	110	33.00	
25	324	303.99	26	14.40		26	127	63	28	89	17.20		38	157	100	40	110	35.00	
26	337	316.09	26	15.50		26	137	71	28	95	20.90		38	157	100	40	110	39.00	
27	349	328.19	26	17.80		26	137	71	28	95	23.20		38	157	100	40	110	43.90	
28	361	340.29	26	19.20		26	137	71	28	95	25.70		38	157	100	40	110	47.00	
29	373	352.39	26	20.40		26	137	71	28	95	28.40		38	157	100	40	110	47.00	
30	385	364.49	26	21.80		26	137	71	28	95	29.70		38	157	100	40	110	56.80	
31	398	376.60	26	24.60		26	137	71	28	95	32.00		38	157	100	40	110	60.00	
32	410	388.71	26	27.60	26	137	71	28	95	35.00	38	157	100	40	110	67.00			
33	422	400.82	26	30.80	26	147	80	28	103	38.20	38	167	140	45	125	84.30			
34	434	412.93	26	34.10	26	147	80	28	103	42.00	40	167	140	45	125	87.00			
35	446	425.04	26	37.60	26	147	80	28	103	47.60	40	167	140	45	125	98.50			
36	458	437.15	26	41.20	26	147	80	28	103	53.00	40	167	140	45	125	104.00			
38	483	461.37	26	49.00	26	147	80	28	103	58.00	40	167	140	45	125	115.00			
40	507	485.60	26	53.30	26	147	80	28	103	65.20	40	167	140	45	125	121.00			
42	531	509.84	26	62.10	26	167	80	28	103	78.00	40	167	160	45	125	131.60			
44	556	534.07	26	76.70	26														
45	568	546.19	26	84.50	26														
46	580	558.30	26	104.30	26														
48	604	582.54	26	119.80	26														
50	628	606.78	26		26														
54	677	655.26	26		26														
60	157	152.86	26		26														
63	786	764.36	26		26														
70	871	849.22	26		26														
75	932	909.84	26		26														

Note:

- Determine the required bore size less than the Max. value shown above taking strength reduction into consideration.
- The shaded area of the above table indicates heat treated teeth.

STANDARD SPROCKET

TYC 140 = (1-3/4" Pitch)

PITCH 44.45 mm

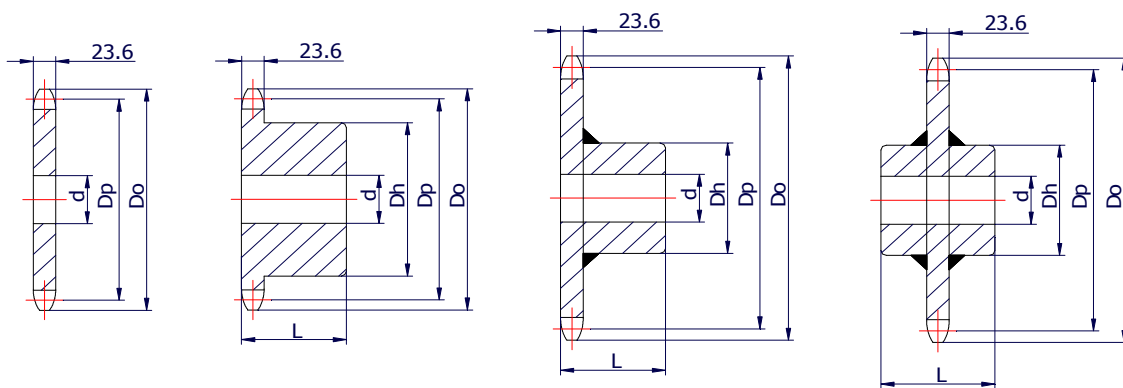

A Type

B type

Welded construction
BW type

Welded construction
CW type

Unit : mm

No. of Teeth	Outside Dia. (Do)	Pitch Dia. (Dp)	Type "A"			Type "B" SINGLE STRAND					Type "C" SINGLE STRAND								
			Stock Bore (d)	Approx. Mass. (kg)	Material	HUB		BORE (d)		Approx. Mass. (kg)	Material	HUB		BORE (d)		Approx. Mass. (kg)	Material		
						Diam. (Dh)	Length (L)	Min.	Max.			Diam. (Dh)	Length (L)	Min.	Max.				
10	163	143.84	28	2.90	SS41	98	56	26	66	4.90	S45C								
11	178	157.77	28	3.60		106	56	26	70	5.50									
12	193	171.74	28	4.20		117	56	26	80	6.60									
13	207	185.74	28	4.90		117	63	26	80	7.90									
14	221	199.76	28	5.70		127	63	26	89	9.30									
15	236	213.79	28	6.36		127	63	26	89	10.10									
16	250	227.84	28	7.50		127	63	26	89	11.00									
17	264	241.91	28	8.40		127	63	26	89	12.00									
18	279	255.98	28	9.40		127	63	26	89	13.00									
19	293	270.06	28	10.50		137	71	26	95	15.60									
20	307	284.14	28	11.60		137	71	26	95	16.70									
21	322	298.24	28	12.80		137	71	26	95	17.90									
22	336	312.34	28	14.10		137	71	26	95	18.40				147	115	33	103	24.00	SS41 CW type (Welding way)
23	350	326.44	28	15.30		137	71	26	95	20.10				147	115	33	103	25.30	
24	364	340.54	28	16.70		137	71	26	95	20.90				147	115	33	103	26.60	
25	379	354.65	28	18.10		147	80	26	103	24.10				147	115	38	103	29.40	
26	393	368.77	28	19.60		147	80	26	103	25.50				147	115	38	103	30.50	
27	407	382.88				147	80	26	103	28.20				147	115	38	103	32.40	
28	421	397.00				147	80	26	103	30.10				147	115	38	103	34.00	
30	450	425.24	28	26.00		147	80	26	103	31.50				147	115	38	103	37.00	
32	478	453.49	28	29.70		147	80	26	103	36.00				147	115	38	103	29.60	
35	521	495.88	28	35.60		157	90	26	110	42.90				157	125	38	110	49.50	
36	535	510.01	28	37.60		157	90	26	110	47.40				157	125	38	110	52.00	
38	563	538.27	28	41.90		157	90	26	110	51.00				157	125	38	110	56.30	
40	591	566.54	28	46.40		157	90	26	110	53.10				157	130	38	110	61.10	
42	620	594.81	28	51.10		157	90	26	110	60.00				157	130	38	110	66.30	
45	662	637.22	28	58.80		167	90	26	118	68.00				167	130	38	118	76.00	
48	705	679.63	28	66.90		167	90	26	118	75.00				167	130	38	118	83.70	
50	733	707.91	28	72.50		167	90	26	118	85.30				167	130	38	118	89.80	
54	790	764.47	28	84.50		167	90	26	118	97.40				167	130	38	118	101.80	
60	875	849.32	28	104.00	167	90	26	118	119.30			167	155	38	118	125.20			

Note:

1. Determine the required bore size less than the Max. value shown above taking strength reduction into consideration.
2. TYC's finishing process is the basic application to the bore surface finishing for doubled sprockets of B type and C type.
3. For double C type sprockets, three or four types of bore size are available in 26 and larger number of teeth than that. The bigger standard bore is applied in case the required bore size ranges between the two types of bore size.
4. Heat treatment on teeth portion is available when requested.

STANDARD SPROCKET

TYC 160 = (2" Pitch)

PITCH 50.80 mm

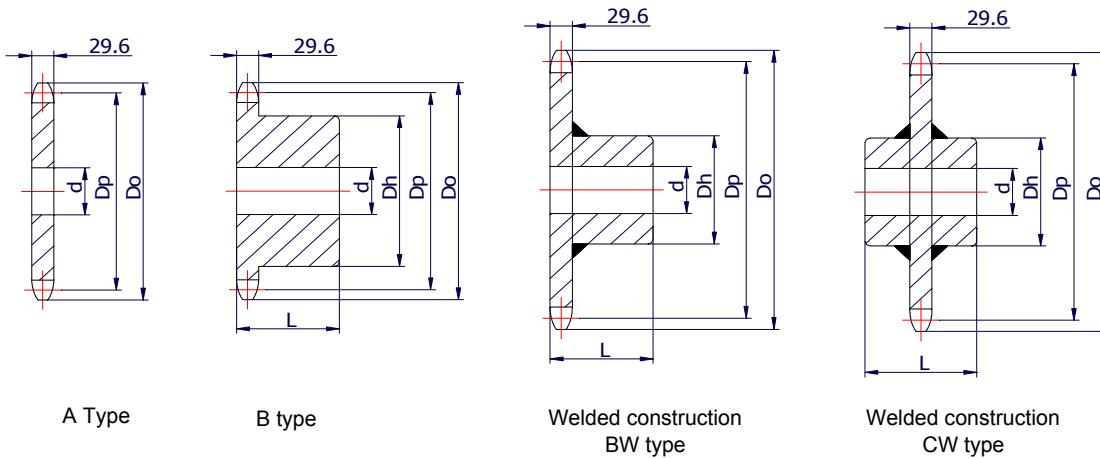

Unit : mm

No. of Teeth	Outside Dia. (Do)	Pitch Dia. (Dp)	Type "A"			Type "B" SINGLE STRAND					Type "C" SINGLE STRAND								
			Stock Bore (d)	Approx. Mass. (kg)	Material	HUB		BORE (d)		Approx. Mass. (kg)	Material	HUB		BORE (d)		Approx. Mass. (kg)	Material		
						Diam. (Dh)	Length (L)	Min.	Max.			Diam. (Dh)	Length (L)	Min.	Max.				
10	187	164.39	26	4.85	SS41	105	63	28	70	6.80	S45C								
11	203	180.31	26	8.85		117	63	28	80	8.30									
12	220	196.28	26	6.90		127	63	28	89	9.90									
13	237	212.27	26	8.10		137	71	28	95	12.50									
14	253	228.29	26	9.40		137	71	28	95	13.80									
15	269	244.33	26	10.80		137	71	28	95	15.20									
16	286	260.39	26	12.25		147	71	28	103	17.40									
17	302	276.46	26	13.80		147	71	28	103	18.90									
18	319	292.55	26	15.50		147	71	28	103	20.60									
19	335	308.64	26	17.20		147	71	28	103	22.30									
20	351	324.74	26	19.00		147	71	28	103	24.20									
21	368	340.84	26	21.00		147	71	38	103	26.10									
22	384	356.96	26	23.00		167	80	38	118	30.20		167	125	38	118	37.80			
23	400	373.07	26	25.10															
24	416	389.19	26	27.40			167	80	38	118		34.40		167	125	38	118	42.20	
25	433	405.32	26	29.70			167	80	38	118		36.60		167	125	38	118	44.50	
26	449	421.45	26	32.10			167	80	38	118		38.90		167	125	38	118	46.90	
28	481	453.72	26																
30	514	485.99	26	42.70			167	100	38	118		52.30		167	125	38	118	57.50	
32	546	518.28	26	48.70			167	100	38	118		59.00		167	125	38	118	64.00	
35	595	566.72	26	58.10			167	100	38	118		66.90		167	125	38	118	74.80	
38	644	615.17	26	68.50															
40	676	647.47	26	75.10			167	100	38	118		88.00		167	150	38	118	94.80	
42	708	679.78	26	83.60															
45	757	728.25	26	96.00		187	100	38	132	93.00		187	150	38	132	120.30			
48	806	776.72	26	109.00		187	100	38	132	101.00		187	150	38	132	133.50			
50	838	809.04	26	118.50		187	100	38	132	138.70		187	150	38	132	143.30			
54	903	873.68	26	138.20		187	100	38	132	158.40		187	150	38	132	163.00			
60	1000	970.65	26	170.00		187	100	38	132	190.80		187	160	38	132	196.60			

Note:

1. Determine the required bore size less than the Max. value shown above taking strength reduction into consideration.
2. TYC's finishing process is the basic application to the bore surface finishing for doubled sprockets of B type and C type.
3. For double C type sprockets, three or four types of bore size are available in 26 and larger number of teeth than that. The bigger standard bore is applied in case the required bore size ranges between the two types of bore size.
4. Heat treatment on teeth portion is available when requested.
5. Due to production reasons, S45C may be used for those with 13 ~ 21 teeth without notice.

STANDARD SPROCKET

TYC 180 = (2-1/4" Pitch)

PITCH 57.15 mm

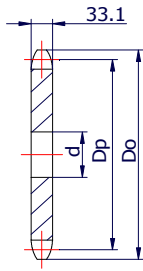

A Type

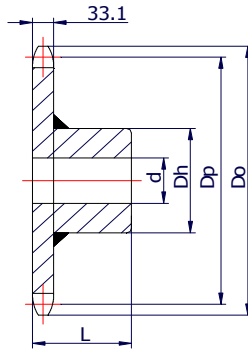

Welded construction
BW type

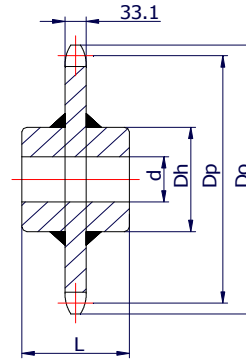

Welded construction
CW type

Unit : mm

No. of Teeth	Outside Dia. (Do)	Pitch Dia. (Dp)	Type "A"			Type "BW" SINGLE STRAND					Type "CW" SINGLE STRAND								
			Stock Bore (d)	Approx. Mass. (kg)	Material	HUB		BORE (d)		Approx. Mass. (kg)	Material	HUB		BORE (d)		Approx. Mass. (kg)	Material		
						Diam. (Dh)	Length (L)	Min.	Max.			Diam. (Dh)	Length (L)	Min.	Max.				
11	229	202.85	43	7.80	SS41	110	55	43	75	9.30	SS41 BW type (Welding way)						SS41 BW type (Welding way)		
12	248	220.81	43	9.30		130	65	43	85	12.60									
13	266	238.81	43	10.90		150	75	43	95	16.60									
14	285	256.83	43	12.60		170	80	43	105	20.90									
15	303	274.88	43	14.50		180	80	43	110	23.80									
16	322	292.94	43	16.50		180	80	43	110	25.90									
17	340	311.02	43	18.70		180	80	43	115	28.10									
18	358	329.11	43	21.50		180	80	43	115	29.90									
19	377	347.22	43	23.90		180	80	43	115	32.40									
20	395	365.33	43	26.60		180	80	43	115	35.00									
21	413	383.45	63	28.90									190	85	63	120		38.80	
22	432	401.57	63	31.70									190	85	63	120		41.70	
23	450	419.71	63	35.00									200	90	63	120		47.80	
24	468	437.84	63	37.90									200	90	63	125		50.20	
25	487	455.98	63	41.20									200	90	63	125		53.50	
26	505	474.13	63	44.60									200	90	63	125		56.80	
27	523	492.28	63	48.50									200	90	63	125		61.30	
28	542	510.43	63	52.20									200	90	63	125		65.00	
30	578	546.74	63	59.60									220	110	63	135		81.10	
32	615	583.06	63	68.40									220	110	63	135		89.60	
34	651	619.39	63	77.20							220	110	63	135	98.50				
35	669	637.56	63	81.30							220	110	63	135	102.90				
36	688	655.72	63	86.70							220	110	63	135	108.00				
38	724	692.06	63	96.60							220	110	63	135	118.00				
40	760	728.41	63	106.40							240	125	63	150	137.50				
42	797	764.75	63	118.20							240	125	63	150	148.90				
45	852	819.28	63	134.80							240	125	63	150	166.10				
48	906	873.81	63	153.50							240	125	63	150	184.90				
50	943	910.17	63	167.7							240	125	63	150	198.60				
54	1016	982.89	63	195.7							240	125	63	150	226.70				
60	1125	1091.98	63	240.2							240	125	63	150	272.20				

Note:

1. Determine the required bore size less than the Max. value shown above taking strength reduction into consideration.
2. Given dimensions of bore and Dh and L of hub to those with 21 teeth and larger is reference. Please consult with us about them when ordering.
3. TYC's finishing process is the basic application to the bore surface finishing for double sprockets of B Type and C type.
4. For double C type sprockets, three or four types of bore size are available in 26 and larger number of teeth than that. The bigger standard bore is applied in case the required bore size ranges between the two types of bore size.
5. Heat treatment on teeth portion is available when requested.

STANDARD SPROCKET

TYC 200 = (2-1/2" Pitch)

PITCH 63.5 mm

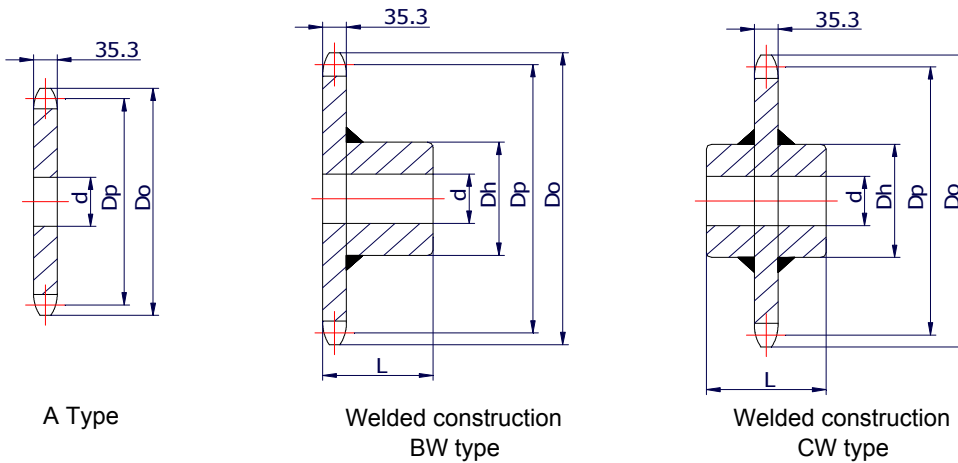

Unit : mm

No. of Teeth	Outside Dia. (Do)	Pitch Dia. (Dp)	Type "A"			Type "BW" SINGLE STRAND						Type "CW" SINGLE STRAND							
			Stock Bore (d)	Approx. Mass. (kg)	Material	HUB		BORE (d)		Approx. Mass. (kg)	Material	HUB		BORE (d)		Approx. Mass. (kg)	Material		
						Diam. (Dh)	Length (L)	Min.	Max.			Diam. (Dh)	Length (L)	Min.	Max.				
11	254	225.39	43	10.40	SS41	147	100	53	90	28.60	SS41 BW Type (Welding way)							SS41 CW Type (Welding way)	
12	275	245.35	43	12.30		163	110	58	100	32.60									
13	296	265.34	43	14.50		182	120	63	110	33.10									
14	316	285.37	43	16.80		182	120	63	110	35.40									
15	337	305.42	43	19.30		182	120	63	110	37.90									
16	357	325.49	43	22.50		197	130	68	120	43.50									
17	378	345.58	43	25.40		197	130	68	120	46.30									
18	398	365.68	63	28.50									197	130	63	120	49.20		
19	419	385.80	63	31.30									197	130	63	120	52.30		
20	439	405.92	63	34.70									210	140	63	130	60.60		
21	459	426.05	63	38.30									210	140	63	130	68.60		
22	480	446.19	63	42.10									210	140	63	130	71.90		
23	500	466.34	63	46.50									210	140	63	130	75.60		
24	520	486.49	63	50.30									210	140	63	130	79.60		
25	541	506.65	63	54.60									227	150	63	140	80.40		
26	561	526.81	63	59.10									227	150	63	140	84.70		
28	602	567.14	63	69.10									227	150	63	140	93.70		
30	642	607.49	63	78.60									227	150	63	140	103.00		
32	683	647.85	63	90.50									247	160	63	150	115.00		
35	744	708.40	63	107.60									247	160	63	150	117.00		
40	845	809.34	63	186.10									247	160	63	150	138.00		
45	946	910.31	63	178.30									277	180	63	170	181.00		
48	1007	970.90	63	202.80									277	180	68	170	193.00		
50	1047	1011.30	63	221.6									277	180	68	170	203.00		
55	1149	1112.30	63	258.6									277	180	68	170	252.00		
60	1250	1213.32	63	317.3									277	180	68	170	262.00		

Note:

1. Determine the required bore size less than the Max. value shown above taking strength reduction into consideration.
2. TYC's finishing process is the basic application to the bore surface finishing for double sprockets of B type and C type.
3. For double C type sprockets, three or four types of bore size are available in 26 and larger number of teeth than that. The bigger standard bore is applied in case the required bore size ranges between the two types of bore size.

STANDARD SPROCKET

TYC 240 = (3" Pitch)

PITCH 76.2 mm

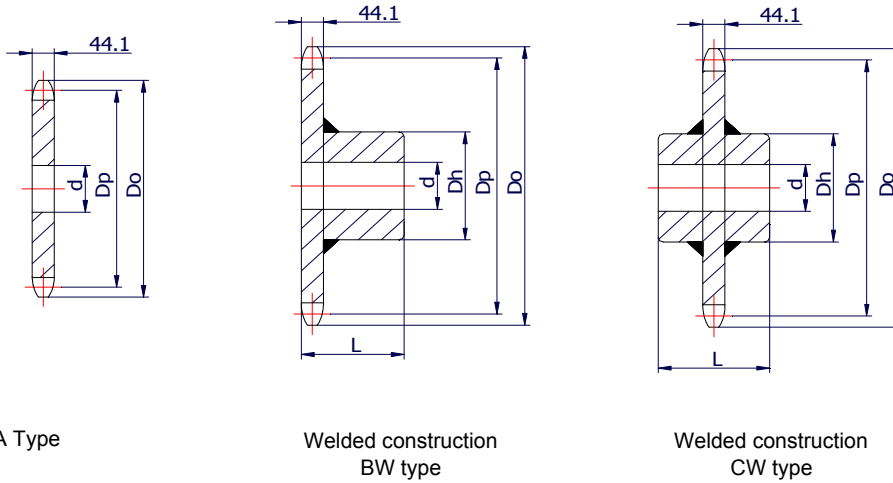

Unit : mm

No. of Teeth	Outside Dia. (Do)	Pitch Dia. (Dp)	Type "A"			Type "BW" SINGLE STRAND					Type "CW" SINGLE STRAND								
			Stock Bore (d)	Approx Mass. (kg)	Material	HUB		BORE (d)		Approx Mass. (kg)	Material	HUB		BORE (d)		Approx Mass. (kg)	Material		
						Diam. (Dh)	Length (L)	Min.	Max.			Diam. (Dh)	Length (L)	Min.	Max.				
11	305	270.47	43	18.90	SS41	177	100	68	110	27.90	SS41 BW Type (Welding way)						SS41 CW Type (Welding way)		
12	330	294.41	43	22.50		187	100	68	120	32.90									
13	355	318.41	43	26.80		187	100	68	120	36.90									
14	380	342.44	43	31.10		187	100	68	120	41.10									
15	404	366.50	63	35.20		187	100	68	120	45.70									
16	429	390.59	63	40.10									197	105	68	125		54.70	
17	453	414.70	63	45.30									197	105	68	125		60.00	
18	478	438.82	63	50.90									197	105	68	125		55.70	
19	502	462.96	63	56.80									197	105	68	125		71.30	
20	527	487.11	63	63.00									197	105	68	125		77.50	
21	551	511.26	63	69.50									197	105	68	125		83.90	
22	576	535.43	63	76.30									197	105	68	125		90.70	
23	600	559.61	63	84.10									197	105	68	125		98.40	
24	625	583.79	63	91.00									197	105	68	125		106.00	
25	649	607.98	63	98.70									197	105	68	125		114.00	
30	771	728.99	63	142.40							227	160	83	145	175.00				
35	892	850.07	63	233.00							227	160	83	145	228.00				
40	1014	971.21	63	253.50							247	170	88	155	295.00				
45	1135	1092.37	63	321.10							247	170	88	155	362.00				
50	1257	1213.56	63	399.20							247	170	88	155	440.00				

- Note:
1. Determine the required bore size less than the Max. value shown above taking strength reduction into consideration.
 2. TYC's finishing process is the basic application to the bore surface finishing for double sprockets of B type and C type.
 3. For double C type sprockets, three or four types of bore size are available in 26 and larger number of teeth than that. The bigger standard bore is applied in case the required bore size ranges between the two types of bore size.