

UL CERTIFIED DOME ALARM BELLS

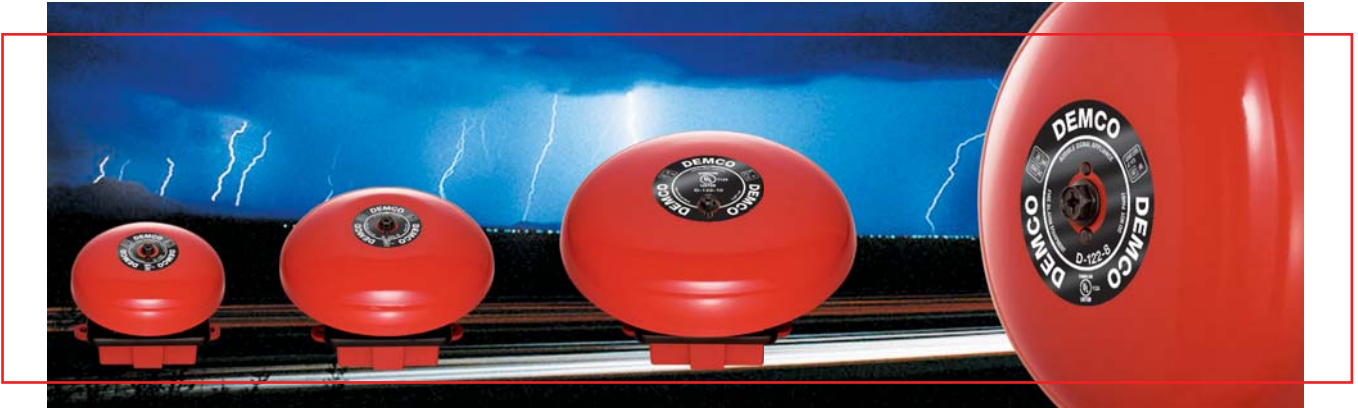

DESCRIPTION

DEMCO UL Certified Dome Alarm Bell series is designed to meet the needs of fire fighting and detection system with central control panel. The UL 464 listed DEMCO Alarm Bells embraced simplicity in design. They incorporate fewer working parts, easy to be installed and operate at high level of efficiency thus enable them to perform under most adverse conditions.

SIGNALING

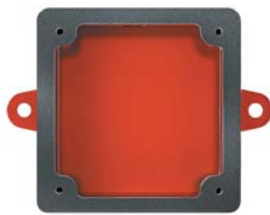

Demco Weatherproof 4" Square Outlet Box

DEMCO ADVANTAGES

- UL approved.
- High sound level output.
- Low power consumption.
- 6", 8" and 10" dome sizes.
- Quick and easy installation.
- Interchangeable base.
- Zero standby current.
- Low current consumption for efficient operation over long wire runs.
- Loud, distinctive and clear ringing sound.
- Corrosion resistant finish.
- IP 65 rated weatherproof (Mount to Demco 4" square outlet box).
- Universal applications.

DECIBEL RATINGS/SPECIFICATIONS

MODEL	SIZE	DECIBEL RATING @ 3M (10 FT)	Gross Weight
D-122	6"	95 dB	700 g
D-122-8	8"	83 dB	1,150 g
D-122-10	10"	85 dB	1,600 g

Details are for motorized bells only. Additional info available upon request. Specifications are subject to change without prior notice.

AVAILABLE MODELS

MODEL	SIZE	TYPE	VOLTAGE
D-122	6"	Motorized	24V DC
D-122-8	8"	Motorized	24V DC
D-122-10	10"	Motorized	24V DC
D-142-6	6"	Solenoid	6V DC
D-142-12	6"	Solenoid	12V DC
D-142	6"	Solenoid	24V DC
D-142-120	6"	Solenoid	120V AC
D-142-220	6"	Solenoid	220V AC
D-142WP-6	6"	Solenoid	6V DC
D-142WP-12	6"	Solenoid	12V DC
D-142WP	6"	Solenoid	24V DC
D-142WP-120	6"	Solenoid	120V AC
D-142WP-220	6"	Solenoid	220V AC

WP = Weatherproof

OPTIONAL IP65 RATED WEATHERPROOF SQUARE OUTLET BOX (FOR OUTDOOR USE)

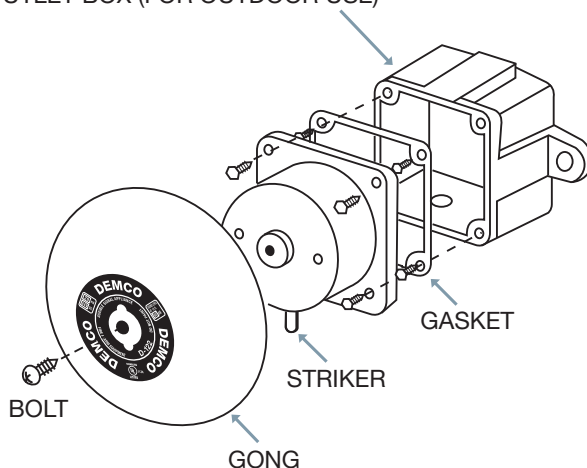

Lot 3928, Jalan Keretapi Lama
Off Jalan Kapar 5 1/2 Miles
42100 Klang
Selangor Darul Ehsan
West Malaysia
Tel: +603-3290 3333
Fax: +603-3290 2288
E-mail: sales@demcoalarm.com



Quality without Compromise