

NDIR Gas Analyzer

ZPA, ZPB, ZPG

Outstanding Sensitivity and Stability

- ✓ 0–5 ppm low-range measurement (ZPG)
- ✓ Continuous and simultaneous measurement of up to 5 components (ZPA, ZPB)
- ✓ Excellent zero-point stability: $\pm 0.5\%$ FS per week (ZPB, ZPG)
- ✓ Easy-to-see LCD



ZPA



ZPB



ZPG

Long-term stability for a wide range of



Single-Beam NDIR Sensor

Repeatability: $\pm 0.5\%$ FS or better Simple structure for ease of maintenance

Principle

The mass flow sensor measures the amount of infrared absorbed in the measurement cell.

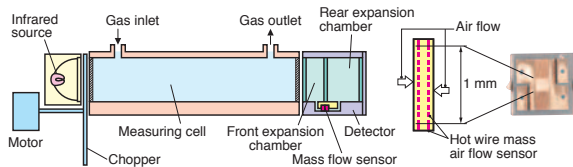

Mass flow sensor

Converts the amount of infrared absorption into electrical signals. Excellent noise resistance thanks to the low impedance sensor. The absence of moving parts makes the device resistant to vibration and semi-permanently usable.

Sample-Switching Method

- Low-level CO₂ and CO: 0–5 ppm
- Long-term superior stability: zero drift $\pm 0.5\%$ FS per week

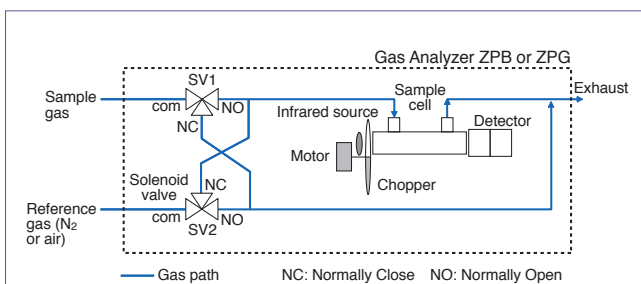

Because the single-beam system is susceptible to temperature change and contamination in the measuring cell, the measurement range in this method is usually 0–100 ppm at the best. By using the sample-switching method, ZPB and ZPG can deliver stable measurement for the range as low as 0–5 ppm.

The analyzer has a motor-operated valve that switches between the sample gas and the reference gas (zero gas) at a certain cycle. This allows the analyzer to keep the zero point accurate and to deliver stable measurement.

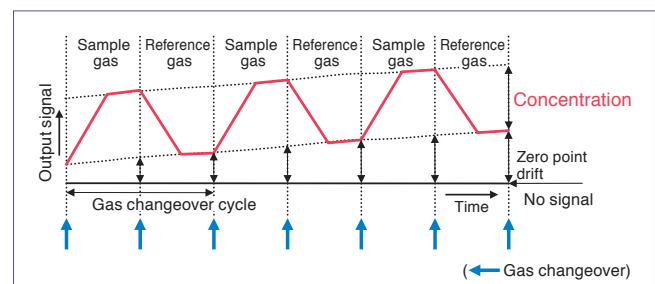

In the sample-switching method, the zero point drift is ignored and the measured values exactly correspond to the concentration difference between the sample gas and the reference gas. Thus, the analyzer can deliver accurate and stable measurement even in the range close to the zero point.

concentrations

Applications

- Refuse incineration plants
- Boiler equipment
- Incinerators, industrial furnaces
- Air separation plants (ZPG)



ZPG: low-concentration measurement

Versatile functionality

Standard functions Optional functions

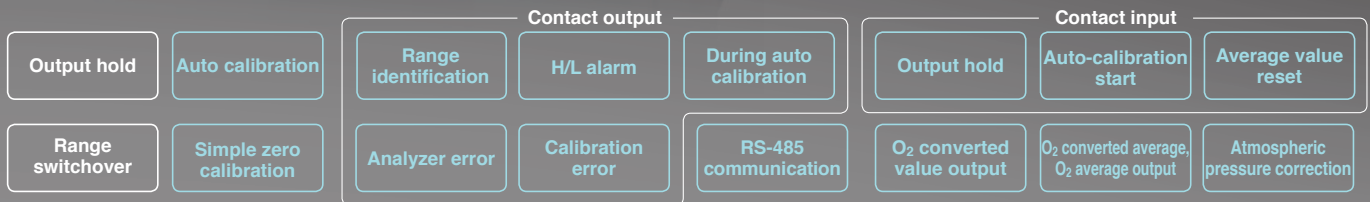

Tolerant to Interference

Interference from moisture and other gases is reduced by the compensation function and the sample-switching method (ZPB and ZPG).

Interference gas	CO ₂ analyzer	CO analyzer	CH ₄ analyzer	SO ₂ analyzer	NO analyzer
CO 1000 ppm	≤ ±1% FS	–	≤ ±1% FS	≤ ±1% FS	≤ ±1% FS
CO ₂ 15%	–	≤ ±1% FS* ¹	≤ ±1% FS	≤ ±1% FS	≤ ±1% FS* ²
H ₂ O saturation at 20°C	≤ ±1% FS	≤ ±1% FS* ³	≤ ±1% FS	–	–
H ₂ O saturation at 2°C	–	≤ ±2% FS	–	≤ ±2% FS	≤ ±2% FS
CH ₄ 1000 ppm	≤ ±1% FS	≤ ±1% FS	–	≤ 20 ppm	–

*1: 0–200 ppm range: ≤ 2% FS

*2: 0–500 ppm range: ≤ 2% FS

*3: 0–500 ppm range: ≤ 2% FS

Interference for 0–200 ppm range may be greater than 2.0% FS depending on conditions.

Easy-to-See LCD



Atmospheric Pressure Compensation (option)

The adverse effect by fluctuations in atmospheric pressure is greatly eliminated.

ZPG Application Example

Measurement of low-level CO₂ and CO in air separating plants

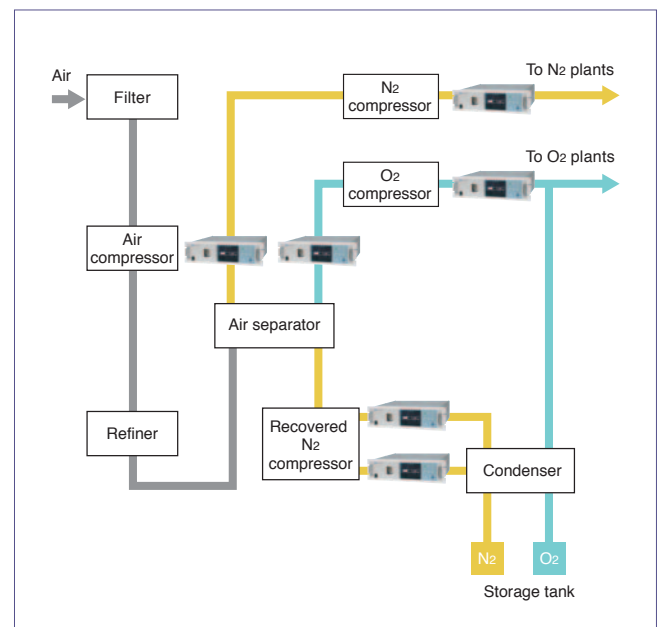

Single beam

5 components max.

NO

SO₂

CO₂

CO

CH₄

O₂

Standard type ZPA



	Min.	Max.
NO	0 ... 200 ppm	0 ... 5000 ppm
SO ₂	0 ... 200 ppm	0 ... 10 vol%
CO ₂	0 ... 100 ppm	0 ... 100 vol%
CO	0 ... 200 ppm	0 ... 100 vol%
CH ₄	0 ... 500 ppm	0 ... 100 vol%
O ₂	0 ... 5 vol%	0 ... 100 vol%

The O₂ ranges above are for the built-in magnetic analyzer.

System configuration example

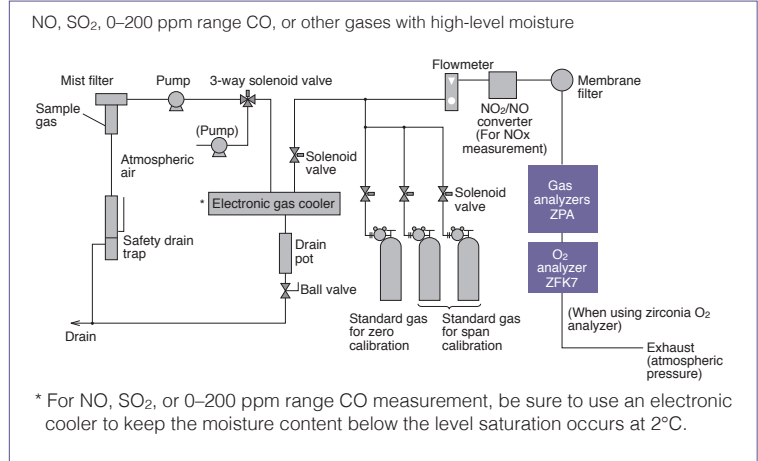

Single beam

Sample switching

5 components max.

NO

SO₂

CO₂

CO

O₂

Drift-less type ZPB



	Min.	Max.
NO	0 ... 50 ppm	0 ... 5000 ppm
SO ₂	0 ... 50 ppm	0 ... 5000 ppm
CO ₂	0 ... 50 ppm	0 ... 25 vol%
CO	0 ... 50 ppm	0 ... 5000 ppm
O ₂	0 ... 5 vol%	0 ... 100 vol%

The O₂ ranges above are for the built-in magnetic analyzer.

System configuration example

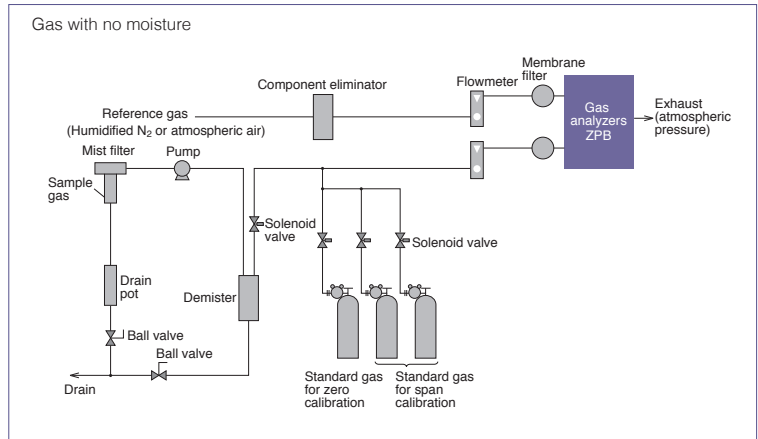

Single beam

Sample switching

2 components max.

NO

SO₂

CO₂

CO

O₂

Low-concentration measurement ZPG



	Min.	Max.
NO	0 ... 10 ppm	0 ... 100 ppm
SO ₂	0 ... 10 ppm	0 ... 100 ppm
CO ₂	0 ... 5 ppm	0 ... 50 ppm
CO	0 ... 5 ppm	0 ... 50 ppm
O ₂	0 ... 5 vol%	0 ... 100 vol%

The O₂ ranges above are for the built-in magnetic analyzer.

System configuration example

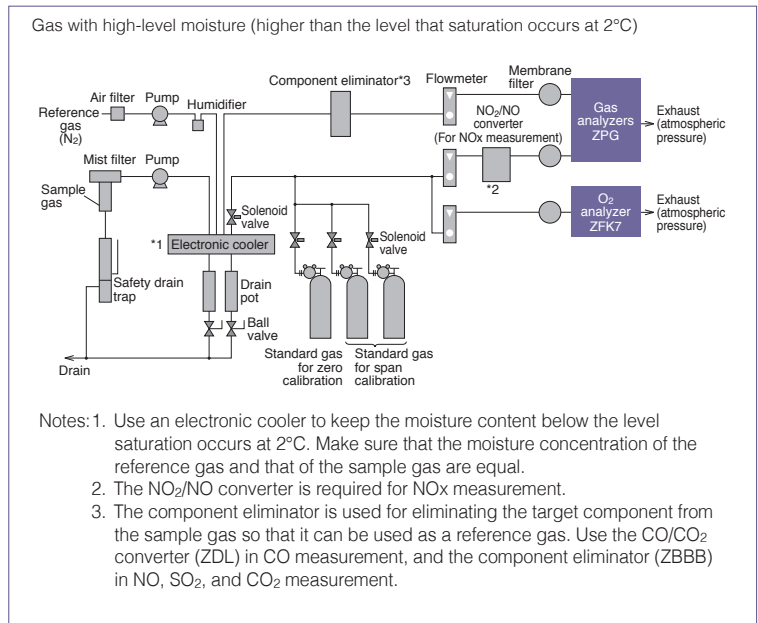

Specifications

	Standard version		Drift-less type		Low-concentration measurement type	
Model	ZPA		ZPB		ZPG	
Principle	NDIR (single beam) O ₂ : magnetic, galvanic, or external zirconia analyzer					
No. of components	≤ 5 (including O ₂)				≤ 2 (including O ₂)	
Components and ranges	Min	Max	Min	Max	Min	Max
NO	0 ... 200 ppm	0 ... 5000 ppm	0 ... 50 ppm	0 ... 5000 ppm	0 ... 10 ppm	0 ... 100 ppm
SO ₂	0 ... 200 ppm	0 ... 10 vol%	0 ... 50 ppm	0 ... 5000 ppm	0 ... 10 ppm	0 ... 100 ppm
CO ₂	0 ... 100 ppm	0 ... 100 vol%	0 ... 50 ppm	0 ... 25 vol%	0 ... 5 ppm	0 ... 50 ppm
CO	0 ... 200 ppm	0 ... 100 vol%	0 ... 50 ppm	0 ... 5000 ppm	0 ... 5 ppm	0 ... 50 ppm
CH ₄	0 ... 500 ppm	0 ... 100 vol%	–	–	–	–
O ₂ (built-in galvanic analyzer)	0 ... 10 vol%	0 ... 25 vol%	0 ... 10 vol%	0 ... 25 vol%	0 ... 10 vol%	0 ... 25 vol%
O ₂ (built-in magnetic analyzer)	0 ... 5 vol%	0 ... 100 vol%	0 ... 5 vol%	0 ... 100 vol%	0 ... 5 vol%	0 ... 100 vol%
O ₂ (external zirconia analyzer)	None	100 ... 95 vol%	–	–	–	–
O ₂ (external zirconia analyzer)	0 ... 5 vol%	0 ... 25 vol%	0 ... 5 vol%	0 ... 25 vol%	0 ... 5 vol%	0 ... 25 vol%
No. of ranges	Up to 2 ranges per component					
Repeatability	±0.5% FS					
Linearity	±1% FS					
Zero drift	±2% FS per week		±0.5% FS per week			
Span drift	±2% FS per week		±2% FS per week			
Response time (for 90%)	10 s ... 30 s (may vary with measurement range)		≤ 30 s Dead time varies within 5–20 seconds according to the setting for the sample switching.			
Output signal	4–20 mA DC or 0–1 V DC (ZPA and ZPB: ≤ 12 points, ZPG: ≤ 4 points)					
Display	LED-backlit LCD, instantaneous value, O ₂ corrected instantaneous value, O ₂ corrected average value, O ₂ average					
Range switching	by key operation, automatic, or remotely (option)					
Contact input (option)	Voltage input: remote range-switching, auto-calibration remote start, remote hold, average reset					
Contact output (option)	SPDT relay contact: analyzer error, calibration error, range identification, during auto-calibration, solenoid valve operation for auto-calibration, H/L limit alarm, CO peak alarm					
Atmospheric pressure correction (option)	Built-in option available					
Standard functions	Output hold, auto/manual range switching					
Optional functions	Auto calibration, auto calibration remote start, remote hold of output, range identification contact output, H/L limit alarm, O ₂ correction, O ₂ -corrected average values, average resetting contact input, CO peak alarm contact output					
Communication (option)	RS-485 (Modbus)					
Sample gas flow checker	None		Provided			
Gas inlet/outlet	Rc ¹ / ₄ or NPT ¹ / ₄ internal thread					
Purge gas flow rate	1 L/min (as needed)					
Reference gas	Not required		Required (dry N ₂ or dry air)			
Operating environment	-20°C ... +60°C, RH 90% or lower (no condensation)					
Mounting	19-inch rack mounting					
Power supply voltage	100–240 V AC, 50/60 Hz					
Power consumption	Approx. 100 VA		Approx. 120 VA		Approx. 100 VA	
Dimensions	483 (W) × 133 (H) × 382 (D) mm					
Weight	Approx. 11 kg		Approx. 13 kg		Approx. 11 kg	

Dimensions

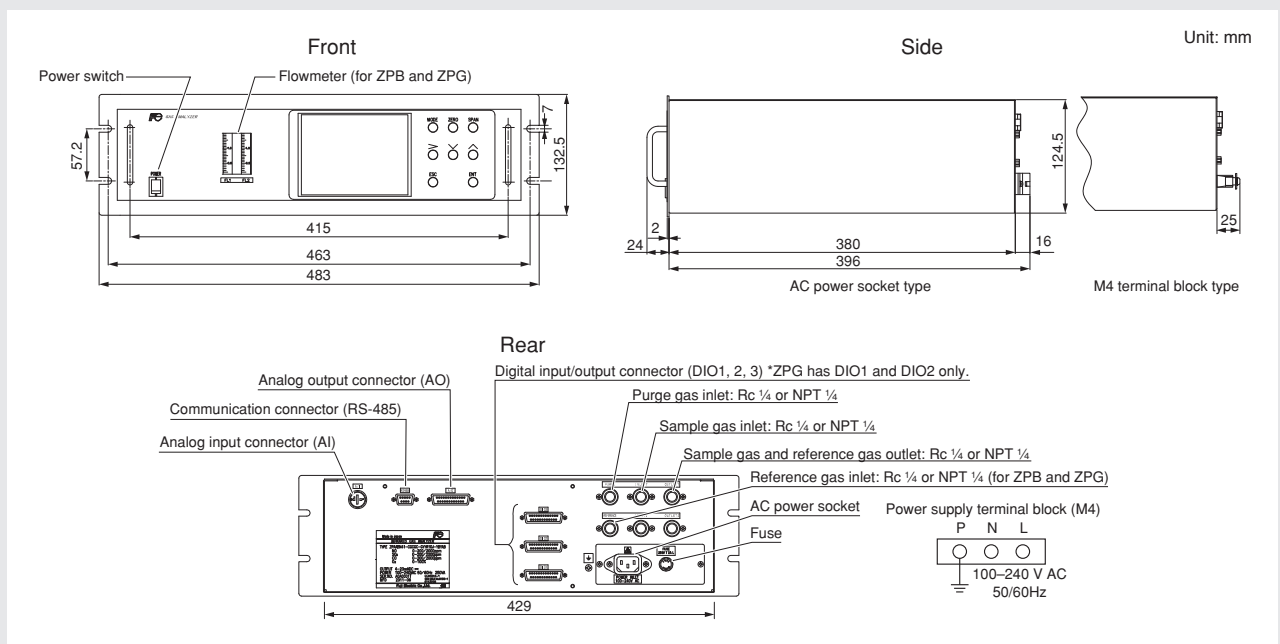

Ordering code

ZPA

4 5 6 7 8 9 10 11 12 13 14 15 16 17 18 19 20 21 22 23 24 25

Z P A **B** **2** -

Digit	Specifications	Note	Code
4	Design / Power Connector Horizontal, with power terminal block Horizontal, with AC power socket		A D
5	Installation 19-inch rack mounting (EIA-compliant)	Note 1	B
6	Component (NDIR)		
	1st 2nd 3rd 4th	Note 2	Y P A D B E F G J K L N T V Z
7	O₂ Sensor None External O ₂ analyzer Zirconia O ₂ analyzer (ZFK7) Galvanic fuel cell sensor Paramagnetic sensor	Note 3	Y 1 2 3 4
8	Revision Code		2
9	(NDIR) 1st component 1st range	Note 4	<input type="checkbox"/>
10	(NDIR) 1st component 2nd range	Note 4	<input type="checkbox"/>

Digit	Specifications	Note	Code
11	(NDIR) 2nd component 1st range	Note 4	<input type="checkbox"/>
12	(NDIR) 2nd component 2nd range	Note 4	<input type="checkbox"/>
13	(NDIR) 3rd component 1st range	Note 4	<input type="checkbox"/>
14	(NDIR) 3rd component 2nd range	Note 4	<input type="checkbox"/>
15	(NDIR) 4th component 1st range	Note 4	<input type="checkbox"/>
16	(NDIR) 4th component 2nd range	Note 4	<input type="checkbox"/>
17	O₂ Range None 0 ... 5 / 0 ... 10 vol% 0 ... 5 / 0 ... 25 vol% 0 ... 10 / 0 ... 25 vol% 0 ... 5 vol% 0 ... 10 vol% 0 ... 25 vol% 0 ... 50 vol% 0 ... 100 vol% 100 ... 95 vol% Others	Note 4	Y A B C L M V P R S Z
18	Gas Inlet/Outlet Rc 1/4 NPT 1/4		1 2
19	Output 0-1 V DC 4-20 mA DC 0-1 V DC + Communication 4-20 mA DC + Communication		A B C D
20	Language / Power Cable Japanese/Power cable rated 125 V (PSE) English/Power cable rated 125 V (UL) English/Power cable rated 250V (CEE) Chinese/Power cable rated 250V (CCC)	Note 5	J E U C

Digit	Specifications	Note	Code
21	O₂-Correction None O ₂ -corrected concentration O ₂ -corrected average concentration O ₂ -corrected concentration + O ₂ -corrected average concentration	Note 6	Y A B C
22	Option (DIO)	Note 7	
	FAULT Auto calibration H/L alarm Range ID, Remote range		Y A B C D E F G H
23	Atmospheric Pressure Correction None Provided		Y 1
24	Unit ppm, vol% mg/m ³ , g/m ³	Note 8	A B
25	Adjustment Standard For heat treatment furnaces For converters Others	Note 9 Note 10	A C D Z

NDIR range codes (for ZPA)

Measurement range	9th-16th codes
None	Y
0 ... 100 ppm	B
0 ... 200 ppm	C
0 ... 250 ppm	D
0 ... 300 ppm	S
0 ... 500 ppm	E
0 ... 1000 ppm	F
0 ... 2000 ppm	G
0 ... 2500 ppm	U
0 ... 3000 ppm	T
0 ... 5000 ppm	H
0 ... 1 vol%	J
0 ... 2 vol%	K
0 ... 3 vol%	Q
0 ... 5 vol%	L
0 ... 10 vol%	M
0 ... 20 vol%	N
0 ... 25 vol%	V
0 ... 40 vol%	W
0 ... 50 vol%	P
0 ... 70 vol%	X
0 ... 100 vol%	R
Others	Z

O₂ range codes (for ZPA, ZPB, ZPG)

Measurement range	17th code	Galvanic fuel cell	Paramagnetic sensor	Zirconia O ₂ analyzer (ZFK7)
0 ... 5 / 0 ... 10 vol%	A		<input type="checkbox"/> Note 11	<input type="checkbox"/>
0 ... 5 / 0 ... 25 vol%	B		<input type="checkbox"/> Note 11	<input type="checkbox"/>
0 ... 10 / 0 ... 25 vol%	C	<input type="checkbox"/>	<input type="checkbox"/>	<input type="checkbox"/>
0 ... 5 vol%	L		<input type="checkbox"/> Note 11	<input type="checkbox"/>
0 ... 10 vol%	M	<input type="checkbox"/>	<input type="checkbox"/>	<input type="checkbox"/>
0 ... 25 vol%	V	<input type="checkbox"/>	<input type="checkbox"/>	<input type="checkbox"/>
0 ... 50 vol%	P		<input type="checkbox"/>	
0 ... 100 vol%	R		<input type="checkbox"/>	
100 ... 95 vol%	S (for ZPA only)		<input type="checkbox"/>	

ppm-mg/m³ conversion table

9th-16th codes	Range in ppm	Range in mg/m ³		
		NO	SO ₂	CO
C	0 ... 200 ppm	0 ... 260 mg/m ³	0 ... 570 mg/m ³	0 ... 250 mg/m ³
D	0 ... 250 ppm	0 ... 325 mg/m ³	0 ... 700 mg/m ³	0 ... 300 mg/m ³
S	0 ... 300 ppm	0 ... 400 mg/m ³	0 ... 850 mg/m ³	0 ... 375 mg/m ³
E	0 ... 500 ppm	0 ... 650 mg/m ³	0 ... 1400 mg/m ³	0 ... 600 mg/m ³
F	0 ... 1000 ppm	0 ... 1300 mg/m ³	0 ... 2800 mg/m ³	0 ... 1250 mg/m ³
G	0 ... 2000 ppm	0 ... 2600 mg/m ³	0 ... 5600 mg/m ³	0 ... 2500 mg/m ³
U	0 ... 2500 ppm	0 ... 3300 mg/m ³	0 ... 7100 mg/m ³	0 ... 3000 mg/m ³
T	0 ... 3000 ppm	0 ... 4000 mg/m ³	0 ... 8500 mg/m ³	0 ... 3750 mg/m ³
H	0 ... 5000 ppm	0 ... 6600 mg/m ³	0 ... 14.00 g/m ³	0 ... 6250 mg/m ³

Conversion formula	NO (mg/m ³) = 1.34 × NO (ppm) SO ₂ (mg/m ³) = 2.86 × SO ₂ (ppm) CO (mg/m ³) = 1.25 × CO (ppm)
--------------------	---

Notes:

- If you select the 4th code "D", select the voltage rating for the power cable in the 20th code.
- If you only use this analyzer only for oxygen measurement, select "Y" in the 6th code.
- If you use an external O₂ analyzer (7th code "1"), set 0-1 V DC linear signals from the external O₂ analyzer so that they corresponds to the full scale setting of the analyzer. Note that the external O₂ analyzer (7th code "1") and the external zirconia O₂ sensor ZFK7 (7th code "2") need to be ordered separately.
- See the "availability check table" in Data Sheets for the possible combination of measuring components and ranges. When ordering, use the codes shown in the "NDIR range codes" and the "O₂ range codes."
- Power cable selection in the 20th code is only for the AC power socket type (4th code "D"). If you selected "A" in the 4th code, make choice of the display language only.
- O₂ correction is provided only for NO, SO₂, and CO measurement.
- The code "H" is unavailable for 5 component analyzer. If you select the 4 component analyzer and the 22th code "H", the number of H/L alarm outputs is three at maximum.
- Even if you select "B" in the 24th code, select the range in ppm that is shown in the "NDIR range codes" table. We will set the analyzer after converting the ppm ranges into mg/m³ ranges. For the converted ranges, see the "ppm-mg/m³ conversion table".
- The adjustment is performed with the following gas.
A: Standard adjustment: balance gas N₂
C: For heat treatment furnace: CO₂ analyzer: 25% CO + 30% H₂ + balance N₂
CO analyzer: 5% CO₂ + 30% H₂ + balance N₂
CH₄ analyzer: 25% CO + 30% H₂ + balance N₂
D: For converter: balance gas CO and CO₂
To order non-standard adjustment, select "Z" and provide us the gas composition data.
- The 25th code "C" is incompatible with the NDIR range codes "X" and "R".
- Incompatible with the NDIR range codes "V", "W", "P", "X", and "R".

ZPB

Z P B

4	5	6	7	8
B			2	

 -

9	10	11	12	13

 -

14	15	16	17	18	19	20

 -

21	22	23	24	25

Digit	Specifications	Note	Code
4	Design / Power Connector Horizontal, with power terminal block Horizontal, with AC power socket	Note 1	A D
5	Installation 19-inch rack mounting (EIA-compliant)		B
6	Component (NDIR)		
	1st 2nd 3rd 4th		
	NO - - -		P
	SO ₂ - - -		A
	CO ₂ - - -		D
	CO - - -		B
	NO SO ₂ - -		F
	NO CO - -		G
	CO ₂ CO - -		J
	NO SO ₂ CO -		N
	NO SO ₂ CO ₂ CO		V
	Others		Z
7	O₂ Sensor None External O ₂ analyzer Zirconia O ₂ analyzer (ZFK7) Galvanic fuel cell sensor Paramagnetic sensor	Note 2	Y 1 2 3 4
8	Revision Code		2
9	(NDIR) 1st component 1st range	Note 3	<input type="checkbox"/>
10	(NDIR) 1st component 2nd range	Note 3	<input type="checkbox"/>
11	(NDIR) 2nd component 1st range	Note 3	<input type="checkbox"/>
12	(NDIR) 2nd component 2nd range	Note 3	<input type="checkbox"/>

Digit	Specifications	Note	Code
13	(NDIR) 3rd component 1st range	Note 3	<input type="checkbox"/>
14	(NDIR) 3rd component 2nd range	Note 3	<input type="checkbox"/>
15	(NDIR) 4th component 1st range	Note 3	<input type="checkbox"/>
16	(NDIR) 4th component 2nd range	Note 3	<input type="checkbox"/>
17	O₂ Range None 0 ... 5 / 0 ... 10 vol% 0 ... 5 / 0 ... 25 vol% 0 ... 10 / 0 ... 25 vol% 0 ... 5 vol% 0 ... 10 vol% 0 ... 25 vol% 0 ... 50 vol% 0 ... 100 vol% Others	Note 3	Y A B C L M V P R Z
18	Gas Inlet/Outlet Rc1/4 NPT1/4		1 2
19	Output 0-1 V DC 4-20 mA DC 0-1 V DC + Communication 4-20 mA DC + Communication		A B C D
20	Language / Power Cable Japanese/Power cable rated 125 V (PSE) English/Power cable rated 125 V (UL) English/Power cable rated 250V (CEE) Chinese/Power cable rated 250V (CCC)	Note 4	J E U C

Digit	Specifications	Note	Code
21	O₂-Correction None O ₂ -corrected concentration O ₂ -corrected average concentration O ₂ -corrected concentration + O ₂ -corrected average concentration	Note 5	Y A B C
22	Option (DIO)	Note 6	
	Fault Auto calibration H/L alarm Range ID, Remote range		
	None		Y
	<input type="radio"/>	<input type="radio"/>	A
	<input type="radio"/>	<input type="radio"/>	B
	<input type="radio"/>	<input type="radio"/>	C
	<input type="radio"/>	<input type="radio"/>	D
	<input type="radio"/>	<input type="radio"/>	E
	<input type="radio"/>	<input type="radio"/>	F
	<input type="radio"/>	<input type="radio"/>	G
	<input type="radio"/>	<input type="radio"/>	H
23	Atmospheric Pressure Correction None Provided		Y 1
24	Unit ppm, vol% mg/m ³ , g/m ³	Note 7	A B
25	Adjustment Standard Others	Note 8	A Z

ZPG

Z P G

4	5	6	7	8
B			2	

 -

9	10	11	12	13

 -

14	15	16	17	18	19	20

 -

21	22	23	24	25

Digit	Specifications	Note	Code
4	Design / Power Connector Horizontal, with power terminal block Horizontal, with AC power socket	Note 1	A D
5	Installation 19-inch rack mounting (EIA-compliant)		B
6	Target (NDIR)		
	NO - - -		P
	SO ₂ - - -		A
	CO ₂ - - -		D
	CO - - -		B
	Others		Z
7	O₂ sensor None External O ₂ analyzer Zirconia O ₂ analyzer (ZFK7) Galvanic fuel cell sensor Paramagnetic sensor	Note 2	Y 1 2 3 4
8	Revision Code		2
9	(NDIR) 1st component 1st range	Note 3	<input type="checkbox"/>
10	(NDIR) 1st component 2nd range	Note 3	<input type="checkbox"/>
11	-		Y
12	-		Y
13	-		Y
14	-		Y
15	-		Y

Digit	Specifications	Note	Code
16	-		Y
17	O₂ Range None 0 ... 5 / 0 ... 10 vol% 0 ... 5 / 0 ... 25 vol% 0 ... 10 / 0 ... 25 vol% 0 ... 5 vol% 0 ... 10 vol% 0 ... 25 vol% 0 ... 50 vol% 0 ... 100 vol% Others	Note 3	Y A B C L M V P R Z
18	Gas Inlet/Outlet Rc1/4 NPT1/4		1 2
19	Output 0-1 V DC 4-20 mA DC 0-1 V DC + Communication 4-20 mA DC + Communication		A B C D
20	Language / Power Cable Japanese/Power cable rated 125 V (PSE) English/Power cable rated 125 V (UL) English/Power cable rated 250V (CEE) Chinese/Power cable rated 250V (CCC)	Note 4	J E U C

Digit	Specifications	Note	Code
21	O₂-Correction None O ₂ -corrected concentration O ₂ -corrected average concentration O ₂ -corrected concentration + O ₂ -corrected average concentration	Note 5	Y A B C
22	Option (DIO)		
	Fault Auto calibration H/L alarm Range ID, Remote range		
	None		Y
	<input type="radio"/>	<input type="radio"/>	A
	<input type="radio"/>	<input type="radio"/>	B
	<input type="radio"/>	<input type="radio"/>	C
	<input type="radio"/>	<input type="radio"/>	D
	<input type="radio"/>	<input type="radio"/>	E
	<input type="radio"/>	<input type="radio"/>	F
	<input type="radio"/>	<input type="radio"/>	G
	<input type="radio"/>	<input type="radio"/>	H
23	Atmospheric Pressure Correction None Provided		Y 1
24	Unit ppm, vol% mg/m ³ , g/m ³	Note 7	A B
25	Adjustment Standard Others	Note 8	A Z

NDIR range codes (for ZPB and ZPG)

Range	Code	Range	Code
None	Y	0 ... 2000 ppm	G
0 ... 5 ppm	5	0 ... 2500 ppm	U
0 ... 10 ppm	6	0 ... 3000 ppm	T
0 ... 20 ppm	7	0 ... 5000 ppm	H
0 ... 25 ppm	8	0 ... 1 vol%	J
0 ... 30 ppm	9	0 ... 2 vol%	K
0 ... 50 ppm	A	0 ... 3 vol%	Q
0 ... 100 ppm	B	0 ... 5 vol%	L
0 ... 200 ppm	C	0 ... 10 vol%	M
0 ... 250 ppm	D	0 ... 20 vol%	N
0 ... 300 ppm	S	0 ... 25 vol%	V
0 ... 500 ppm	E	Others	Z
0 ... 1000 ppm	F		

*1: For ZPB and ZPG
*2: Only for ZPG
*3: Only for ZPB

ppm-mg/m³ conversion table

Code	Range in ppm	Range in mg/m ³		
		NO	SO ₂	CO
5	0 ... 5 ppm	-	-	0 ... 6.00 mg/m ³
6	0 ... 10 ppm	0 ... 13.0 mg/m ³	0 ... 28.0 mg/m ³	0 ... 12.5 mg/m ³
7	0 ... 20 ppm	0 ... 26.0 mg/m ³	0 ... 57.0 mg/m ³	0 ... 25.0 mg/m ³
8	0 ... 25 ppm	0 ... 32.5 mg/m ³	0 ... 70.0 mg/m ³	0 ... 30.0 mg/m ³
9	0 ... 30 ppm	0 ... 40.0 mg/m ³	0 ... 85.0 mg/m ³	0 ... 37.5 mg/m ³
A	0 ... 50 ppm	0 ... 65.0 mg/m ³	0 ... 140 mg/m ³	0 ... 60.0 mg/m ³
B	0 ... 100 ppm	0 ... 130 mg/m ³	0 ... 280 mg/m ³	0 ... 125 mg/m ³
C	0 ... 200 ppm	0 ... 260 mg/m ³	0 ... 570 mg/m ³	0 ... 250 mg/m ³
D	0 ... 250 ppm	0 ... 325 mg/m ³	0 ... 700 mg/m ³	0 ... 300 mg/m ³
S	0 ... 300 ppm	0 ... 400 mg/m ³	0 ... 850 mg/m ³	0 ... 375 mg/m ³
E	0 ... 500 ppm	0 ... 650 mg/m ³	0 ... 1400 mg/m ³	0 ... 600 mg/m ³
F	0 ... 1000 ppm	0 ... 1300 mg/m ³	0 ... 2800 mg/m ³	0 ... 1250 mg/m ³
G	0 ... 2000 ppm	0 ... 2600 mg/m ³	0 ... 5600 mg/m ³	0 ... 2500 mg/m ³
U	0 ... 2500 ppm	0 ... 3300 mg/m ³	0 ... 7100 mg/m ³	0 ... 3000 mg/m ³
T	0 ... 3000 ppm	0 ... 4000 mg/m ³	0 ... 8500 mg/m ³	0 ... 3750 mg/m ³
H	0 ... 5000 ppm	0 ... 6600 mg/m ³	0 ... 14.00 g/m ³	0 ... 6250 mg/m ³

Notes:

- If you select the 4th code "D", select the voltage rating for the power cable in the 20th code.
- If you use an external O₂ analyzer (7th code "1"), set 0-1 V DC linear signals from the external O₂ analyzer so that they corresponds to the full scale setting of the analyzer.
Note that the external O₂ analyzer (7th code "1") and the external zirconia O₂ sensor ZFK7 (7th code "2") need to be ordered separately.
- See the "availability check table" in Data Sheets for the possible combination of measuring components and ranges. When ordering, use the codes shown in the "NDIR range codes" and the "O₂ range codes."
- Power cable selection in the 20th code is only for the AC power socket type (4th code "D"). If you selected "A" in the 4th code, make choice of the display language only.
- O₂ correction is provided only for NO, SO₂, and CO measurement.
- The code "H" is unavailable for 5 component analyzer. If you select the 4 component analyzer and the 22th code "H", the number of H/L alarm outputs is three at maximum.
- Even if you select "B" in the 24th code, select the range in ppm that is shown in the "NDIR range codes" table. We will set the analyzer after converting the ppm ranges into mg/m³ ranges. For the converted ranges, see the "ppm-mg/m³ conversion table".
- The standard adjustment (the 25th code "A") is carried out using N₂ as balance gas. To order non-standard adjustment, select "Z" in the 25th code and provide us the gas composition data.

Conversion formula	NO (mg/m ³) = 1.34 × NO (ppm)	SO ₂ (mg/m ³) = 2.86 × SO ₂ (ppm)	CO (mg/m ³) = 1.25 × CO (ppm)
--------------------	---	---	---

Double-beam

High-performance model ZKJ

5 components max.

NO

SO₂

CO₂

CO

CH₄

N₂O

O₂

- Zero point drift: ±1.0% FS per week
- Maximum range ratio of 1 : 25
- N₂O measurement available
- Hardly affected by interference from other gases
- Calibration, alarm, calculation
- Easy-to-see LCD

	Min.	Max
NO	0 ... 50 ppm	0 ... 5000 ppm
SO ₂	0 ... 50 ppm	0 ... 10 vol%
CO ₂	0 ... 20 ppm	0 ... 100 vol%
CO	0 ... 50 ppm	0 ... 100 vol%
CH ₄	0 ... 200 ppm	0 ... 100 vol%
N ₂ O	0 ... 200 ppm	0 ... 2000 ppm
O ₂	0 ... 5 vol%	0 ... 25 vol%



Double-Beam NDIR Sensor

Principle The mass flow sensor measures the amount of infrared absorbed in the measurement cell.

Double beam method achieves the range ratio of 1 : 25

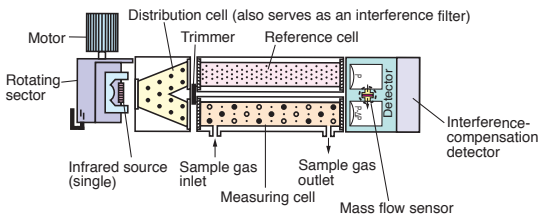

Mass flow sensor

Converts the amount of infrared absorption into electrical signals. Excellent noise resistance thanks to the low impedance sensor. The absence of moving parts makes the device resistant to vibration and semi-permanently usable.

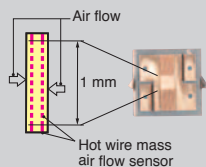

Specifications

Principle	NO, SO ₂ , CO ₂ , CO, CH ₄ , N ₂ O: double-beam NDIR O ₂ : built-in paramagnetic sensor or external zirconia analyzer
Repeatability	±0.5% FS (±1% FS for the ranges below 50 ppm)
Linearity	±1% FS
Zero drift	±1% FS per week (±2% FS per week for 50–200 ppm range)
Span drift	±2% FS per week (±2% FS per day for the ranges below 50 ppm)
Response time (for 90%)	≤ 60 s
Output signal	4–20 mA DC or 0–1 V DC, up to 12 points
External contact input	Dry contact Remote range-switching, auto-calibration remote start, remote hold, average value reset, pump ON/OFF
Contact output	SPST-NO and SPDT relay contacts Analyzer error, calibration error, range identification, under auto-calibration, pump ON/OFF, limit alarm CO peak alarm, H/L limit alarm, power interruption
Communication (separate order item)	RS-232C (Modbus)
Display	LED backlit LCD Instantaneous value, O ₂ -corrected instantaneous value, O ₂ corrected average value, O ₂ average
Power supply voltage	100–240 V AC, 50/60 Hz
Power consumption	250 VA
Dimensions	483 (W) × 177 (H) × 600 (D) mm
Weight	Approx. 22 kg

Information in this catalog is subject to change without notice.
Read the instruction manuals thoroughly before using the products.

F Fuji Electric Co., Ltd.

www.fujielectric.com

Instrumentation & Sensors Planning Dept.

Gate City Ohsaki, East Tower, 11-2, Osaki 1-chome, Shinagawa-ku, Tokyo 141-0032, Japan

Phone: +81-3-5435-7021 Fax: +81-3-5435-7475

www.fujielectric.com/products/instruments/