

T30-FR9 400V/3N/50Hz - 110 Kg - 140 Kg

Tecnomac

T30-110

+110 KG
+90°C → +3°C

-95 KG
+90°C → -18°C

T30-140

+140 KG
+90°C → +3°C

-125 KG
+90°C → -18°C



Carrello - Trolley

GN 2/1 600 x 800 mm
Carrello forni GN 2/1
Trolley of combi-steamers GN2/1

1



Opzioni - Optionals



LAMPADA UV
STERILIZING UV LAMP



STAMPANTE HACCP
HACCP PRINTER



CONDENSAZIONE ACQUA
WATER COOLED CONDENSER



SENZA UNITA' CONDENSATRICE
WITHOUT CONDENSING UNIT



PAVIMENTO H22 mm+ RAMP
FLOOR H22 mm + RAMP



KIT INSTALLAZIONE AGGIUNTIVO
ADDITIONAL INSTALLATION KIT



UNITA' COND. CARENATA
CONDENSING UNIT WITH BOX



UNITA' COND. INSONORIZZATA
SOUNDPROOF CONDENSING UNIT



PORTA AGGIUNTIVA (TUNNEL)
ADDITIONAL DOOR (PASS THROUGH)

Caratteristiche - Features

Codice prodotto	Item code no		T30/110	T30/140
Alimentazione Elettrica	Power Supply		400V/3N/50HZ	400V/3N/50HZ
Lunghezza esterna	Outside length	mm	1370	1370
Altezza esterna	Height	mm	2274	2274
Profondità esterna	Depth	mm	1210	1210
Capacità	Capacity	GN 2/1 - EN 600x800 - Carr. forno/trol.combi-steamers GN 2/1	1 carrello/trolley	1 carrello/trolley
Resa abbattimento	Output chilling	kg (+90°C/+3°C)	110	140
Resa Surgelazione	Output Freezing	kg (+90°C/-18°C)	95	125
Centralina elettronica	Electronic central unit		BASE	BASE
Potenza assorbita	Absorbed power	W Cond:-20°/+40 (°C)	630+4300	630+5100
Corrente Massima	Max Current	A	12	18
Dati spedizione Box - Cassa di legno	Shipping Data Box - Wood box	cm (Kg)	245x146x112 (450)	245x146x112 (450)
Potenza Frigorifera	Refrig. Power	Cond:-20°/+40 (°C)	4 HP	5,5 HP
Cavo alimentazione/controllo	Supply/Control Cable Size		5x2.5/10x1.5mm	5 x 4 mm
Diametro Tubo Mandata	Diameter Discharge Pipe (<15 mt)	mm	12	12
Diametro Tubo Aspirazione	Diameter Suction Pipe (<15 mt)	mm	28	28
Diametro Tubo Gas Caldo	Diameter Hot Gas Pipe (<15 mt)	mm	10	10
Gas	Gas Type		R 404a	R 404a
Dati spedizione u.c cartone	Shipping Data c.u. - Carton	cm - (Kg)	80x155x70 (270)	95x160x85 (310)

T30 FR9 TECNOMAC 400V-3N-50HZ-006.indd

T30-FR9 Abbattitori - Blast Chillers/Freezer

Castel MAC SpA

Via del Lavoro,9 - C.P. 172
I - 31033 Castelfranco Veneto (TV)
ITALY EU

Tel. +39 0423 738452
Fax +39 0423 722811

Tecnomac

T30-FR9 400V/3N/50Hz - 110 Kg - 140 Kg

Tecnomac

T30-FR9 Abbattitori - Blast Chillers/Freezer

DIMENSIONI-DIMENSIONS

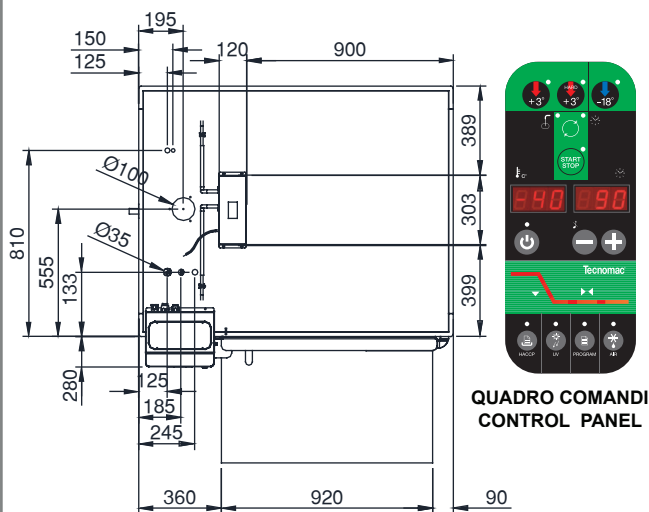
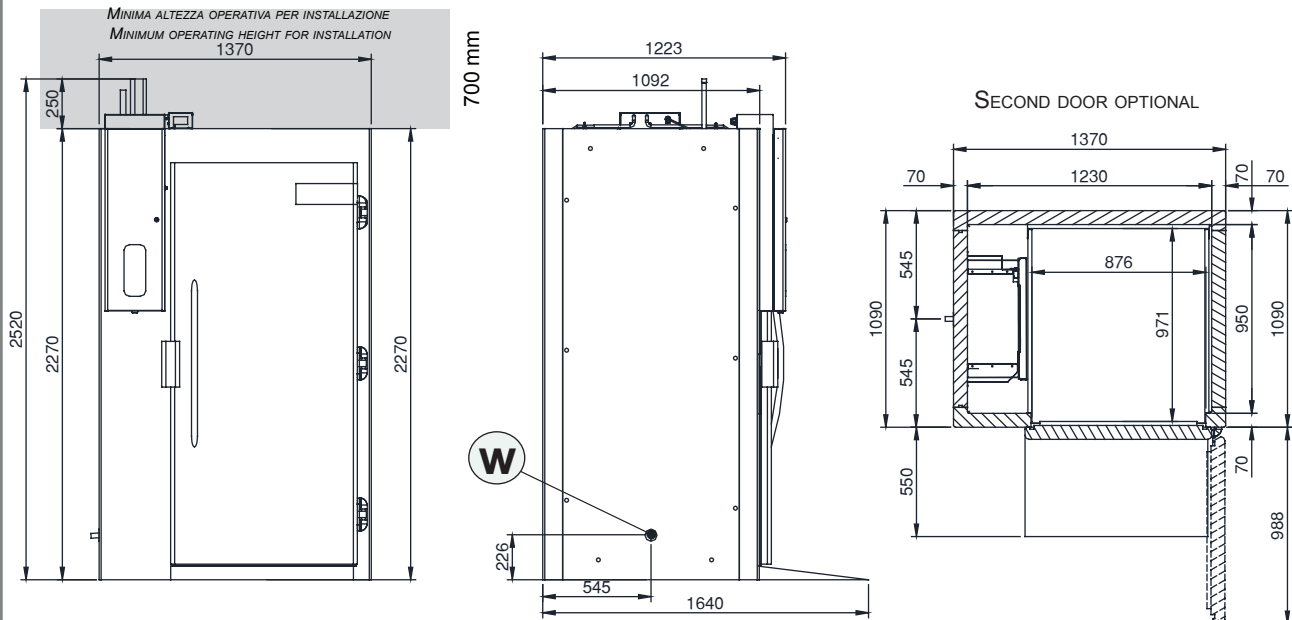

UNITA' REMOTE - REMOTE UNIT FEATURES

- E** ELECTRICAL CABLE SUPPLY
ALIMENTAZIONE ELETTRICA
- W** DRAINAGE DISCHARGE
SCARICO ACQUA

UNITA' CONDENSATRICE
CARENATA

CONDENS. UNIT WITH
BOX

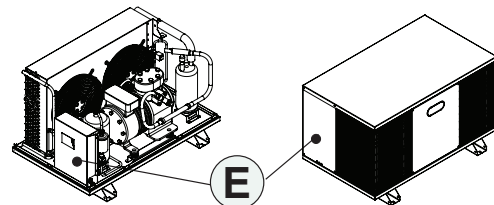

Machine delivered without condensing unit - Disclaimer Clause

Castelmac guarantees only the good functioning of the components of the machine. It's excluded from the warranty:

- the cooling performance of the machine
- malfunctioning or damages due to the partial or not complete connection of the machine with the central cooling unit or the not original condensing unit. In particular there is no warranty on damages on the machine due to the missed connection of the alarm input which stops the machine in case of alarm coming from the central cooling unit or the not original condensing unit. Hot gas defrosting available only if hot gas supplied (distance < 25 m). Alternative air defrosting available from control panel.

Impianto fornito privo di unità condensante Clausole esonerative garanzia

Castelmac garantisce solo il buon funzionamento dei componenti forniti con l'impianto. Sono escluse dalla garanzia:

- le prestazioni frigorifere della macchina
- malfunzionamenti dovuti a parziali o non conformi connessioni della macchina alla unità centrale di refrigerazione o a unità condensanti di terzi. In particolare non garantisce danni derivanti da mancata connessione all'ingresso di allarme reso disponibile dalla scheda elettronica e che permette il blocco dell'impianto, il quale interviene in caso di malfunzionamento della centrale frigorifera o della unità condensante fornita da terzi. Sbrinatorio a gas caldo disponibile solo se viene fornita la linea di gas caldo (distanza < 25m). Sbrinatorio ad aria disponibile da pannello di controllo

T30 FR9 TECNOMAC 400V-3N-50HZ-006.indd

Castel MAC SpA

Via del Lavoro,9 - C.P. 172
I - 31033 Castelfranco Veneto (TV)
ITALY EU

Tel. +39 0423 738452
Fax +39 0423 722811

Tecnomac

T30-FR9 400V/3N/50Hz - 110 Kg - 140 Kg

Tecnomac®

T30-FR9 Abbattitori - Blast Chillers/Freezer

SCAVO - EXCAVATION

Soluzione per funzionamento minore di 16h/giorno

For running , less than 16 hours a day

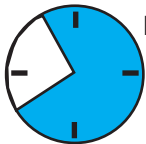

MAX 16h

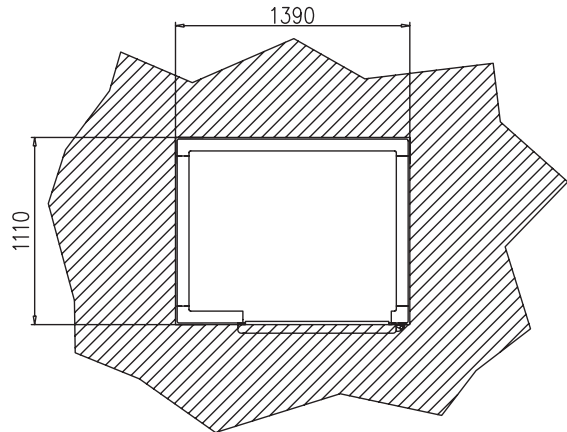
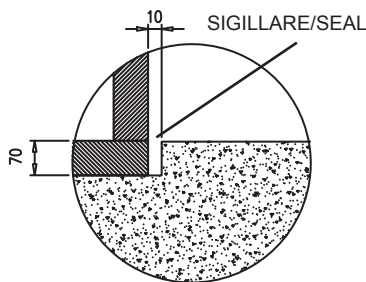

Soluzione per funzionamento 24h/giorno con griglia

For running 24 hours a day with removable gate

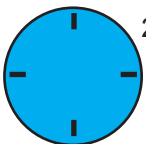

24h

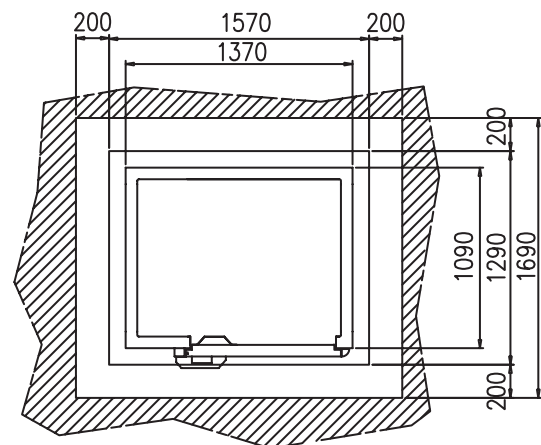
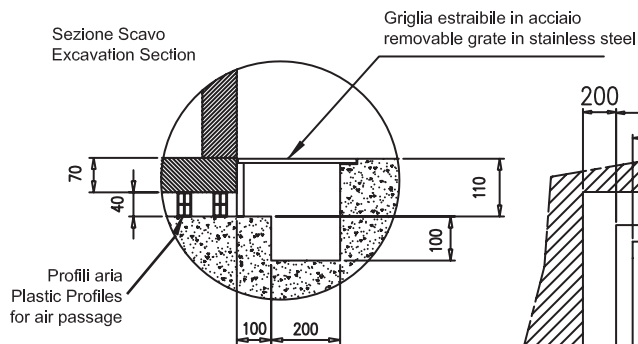

Dettaglio Scavo
Excavation example

T30 FR9 TECNOMAC 400V-3N-50HZ-006.indd

Castel MAC SpA

Via del Lavoro,9 - C.P. 172
I - 31033 Castelfranco Veneto (TV)
ITALY EU

Tel. +39 0423 738452
Fax +39 0423 722811

Tecnomac

T30-FR9 400V/3N/50Hz - 110 Kg - 140 Kg

Tecnomac®

T30-FR9 Abbattitori - Blast Chillers/Freezer

Soluzione per funzionamento 24h/giorno con camini areazione For running 24 hours a day with ventilation chimneys

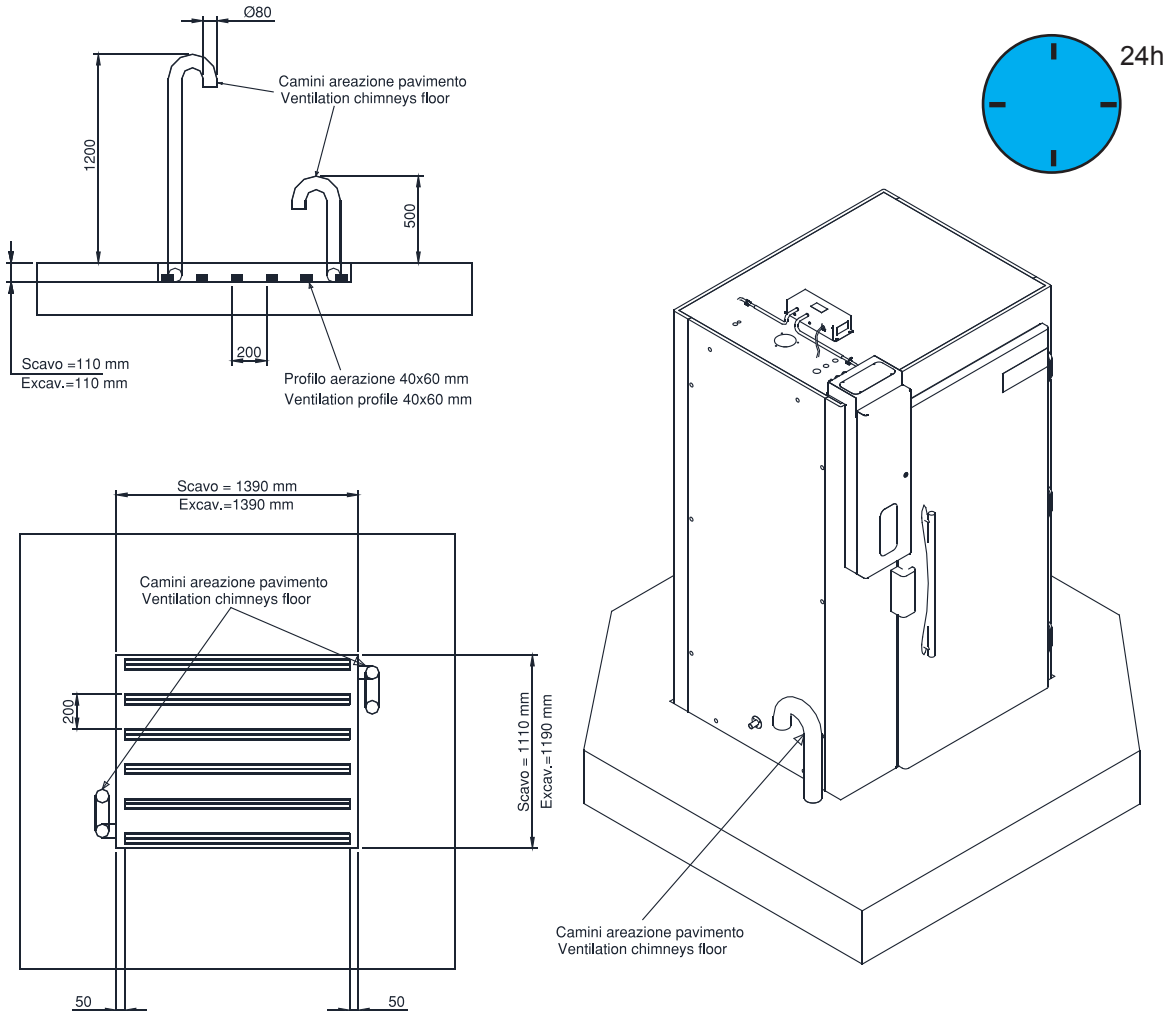

CONNESSIONE A CENTRALE FRIGORIFERA - CONNECTION TO CENTRAL COOLING UNIT

- Deve essere disabilitata la funzione di surgelazione / *Blast Freezing function must be disabled (do not work)*
- Usare linea con temperatura di evaporazione $-28^{\circ}\text{C}/-30^{\circ}\text{C}$ / *Use the freezing line ($-28^{\circ}\text{C} / - 30^{\circ}\text{C}$ Evaporation)*
- Disponibile solo segnale per la valvola di liquido (valvola non fornita) / *Output signal supplied for liquid line valve control (valve not supplied)*
- Disponibile ingresso su scheda elettronica per segnale di allarme dalla centrale frigorifera, che permette di bloccare la macchina / *Input signal available for general alarm from the central cooling unit, which stops the machine*

CONNESSIONE A UNITA' CONDENSANTE FORNITA DA TERZI - CONNECTION TO CONDENSING UNIT NOT SUPPLY BY TECNOMAC

- Fornito segnale di comando per compressore / *Output signal supplied for switch on compressor*
- Fornito segnale di comando per valvola gas caldo (se presente) / *Output signal supplied for switch on hot gas valve (if present)*
- Disponibile ingresso su scheda elettronica per segnale di allarme da unità condensante, che permette di bloccare la macchina / *Input signal available for alarm coming from the condensing unit, which stops the machine*

T30 FR9 TECNOMAC 400V-3N-50HZ-006.indd

Castel MAC SpA

Via del Lavoro,9 - C.P. 172
I - 31033 Castelfranco Veneto (TV)
ITALY EU

Tel. +39 0423 738452
Fax +39 0423 722811

Tecnomac