

CGR-FX

Rotary Gas Meter for fiscal measurements



Rotary gas meters are positive displacement meters, designed to measure quantity of gas, for custody transfer or technical measurement applications.

The CGR-FX Meters are applied in measurement systems where high accuracy is required:

- transportation and distribution of natural gas
- primary and secondary measurements
- control metering of natural gas and non aggressive technical gases in industry
- flow measurement for technical purposes

Being a very precise instruments, resistant to disturbances and having a wide measurement range, the CGR-FX Meters satisfy all technical demands of customers.

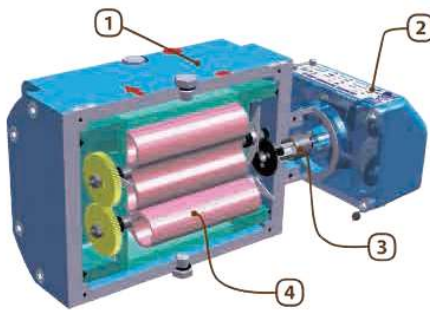

The CGR-FX Meter consists of the following main assemblies:

- Pressure resistant housing (1)
- Index head (2)
- Magnetic coupling (3)
- Measuring assembly (4)

All parts subject to servicing or maintenance, like mechanical counter, LF (HF) sockets, oil filler and drain plugs, oil level sight-glass, are located on the front side of the meter. Thanks to this, it is not necessary to access the back

side of the meter and then it could be located very close to a wall or other construction element what reduces the installation deep.

The gas flow through the rotary gas meter measurement chamber makes the two "8"-shaped rotors to turn. The volume of gas closed between the measuring chamber walls and rotors is transported four times in one full cycle from the meter inlet to the outlet. The timing gears set the rotors at the angle of 90° one to the other. The gear train, and the incorporated gas tight and hermetic magnetic coupling, transfers the rotor rotation to the index unit, which is separated in that way from the pressure tight housing. The actual volume of gas is indicated on the mechanical counter. The measurement cartridge, as a separate unit, is fixed in the pressure resistant housing by means of elastomere gaskets. Thanks to this, the possible stresses, e.g. arising from improperly aligned piping, have no influence on measurement results of the CGR-FX Meter. Moreover, the measuring cartridge elements are made of materials with carefully selected values of thermal expansion coefficients. This minimizes temperature stresses that could cause the rotor seizures. All above factors, together with the highest precision machining of parts allow to reduce small but necessary clearances between the moving rotors and the measurement chamber walls, what reduces gas leakages to minimum and results in very high accuracy and wide measuring ranges of our CGR-FX Meters.

- ✓ pressure rating:
PN16, ANSI150
other on request
- ✓ HTR version available
- ✓ nominal diameter:
DN40 up to DN100
- ✓ meter external housing:
aluminium or cast iron
- ✓ flow:
0.2 to 650 m³/h
- ✓ rangeability:
up to 1:250
(depending on the meter)
- ✓ temperature range:
ambient temperature -25°C to +70°C
- ✓ operating position:
horizontal or vertical
- accuracy class 1,0
according to EN12480 standard:
✓ $Q_t \div Q_{max} < \pm 1\%$
 $Q_{min} \div Q_t < \pm 2\%$
- approvals:
✓ • MID
✓ • PED
✓ • ATEX
- ✓ traceability to PTB standards

Dimensions and weights

Overall dimensions and weights of CGR-FX meters

Serie "171"

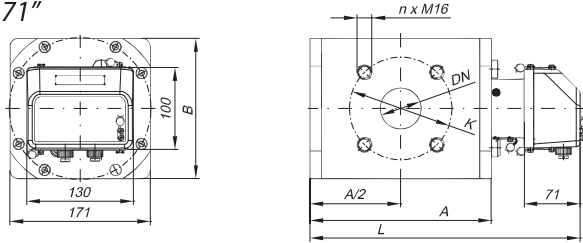

Serie "241"

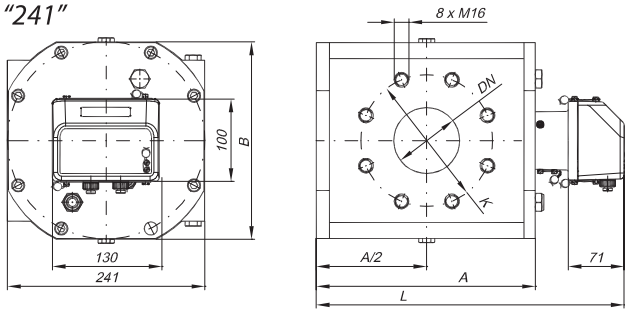

Table 1: Dimensions and weight of rotary gas meters.

	DN [mm]			n	A	B	L	Weight [kg]	Cyclic volume [dm ³]
	40	50	80						
ALUMINIUM HOUSINGS									
G10	+	+		4	165	171	277	10	0,23
G16	+	+		4	165	171	277	10	0,23
G25	+	+		4	184	171	296	12	0,31
G40	+	+		4	225	171	337	14	0,50
G65		+		4	295	171	407	19	0,81
G100		+		4	391	171	503	24	1,24
G100			+	8	391	171	503	24	1,24
G100			+	8	249	241	356	25	1,29
G160			+	8	314	241	421	31	2,00
G250			+	8	439	241	546	42	3,34
G400			+	8	439	241	546	42	3,34
CAST IRON HOUSINGS									
G10	+	+		4	246	181	358	33	0,50
G16	+	+		4	246	181	358	33	0,50
G25	+	+		4	246	181	358	33	0,50
G40	+	+		4	246	181	358	33	0,50
G65		+		4	316	181	428	38	0,81
G100		+		4	412	181	524	45	1,24
G100			+	8	412	181	524	45	1,24
G100			+	8	327	253	439	64	2,00
G160			+	8	327	253	449	64	2,00
G250			+	8	452	253	564	78	3,34
G400			+	8	452	253	564	78	3,34

All information included in the table refer to basic version of the meters. It is possible to manufacture compact version (smaller sizes, higher possible rangeability, higher noise level) and low speed version (bigger sizes, smaller possible rangeability, lower noise level).
Contact your local representative or the producer to get more information about the products.

Metrology

The meters are manufactured in accordance with EC regulations and OIML recommendations. The maximum permissible error, according to EN12480 is $\pm 2\%$ in the range $Q_{min} \div Q_t$ and $\pm 1\%$ in the range $Q_t \div Q_{max}$. Maximum rangeability may be up to 1:250 for larger meters (refer to Table 2).

Outputs

- ✓ As an option the meters can be provided with maximum 6 pulse transmitters
- ✓ 2 off low frequency pulse sensors (LFK reed contact or LFW Wiegand)
- ✓ 2 off LFI – low frequency inductive pulse sensors (NAMUR)
- ✓ 2 off HF – inductive pulse sensors in the index head (NAMUR)
- ✓ AFK – anti-fraud reed contact (available as an option)
- ✓ Amphenol TUCHEL connectors
- ✓ Index housing made of aluminium what perfectly protects index head against accidental damages
- ✓ Index housing may be provided with two separate sockets
- ✓ 2 pressure measurement taps as standard
- ✓ 2 temperature measurement taps (thermowells on request)



Index head with encoder (option)

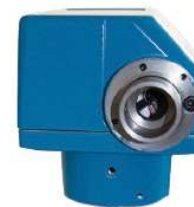

Index head with mechanical output (option)

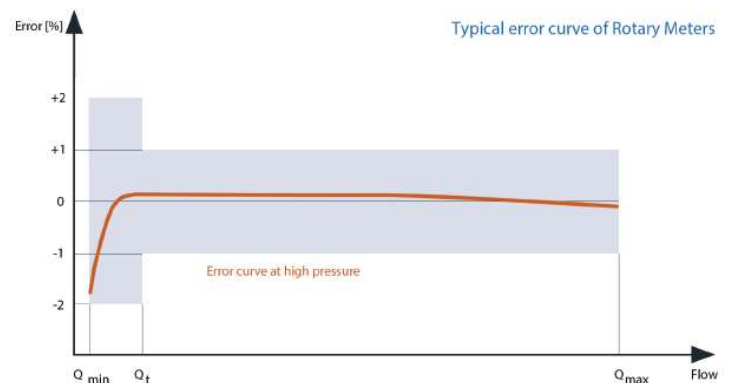

Pressure loss

Pressure drop during the gas flow through the meter according to EN12480 is determined for air at atmospheric conditions.

To calculate pressure drop for other gases at higher pressures, the following formula may be used:

$$\Delta p_{rz} = \rho_w \times \left(\frac{p_a + p}{p_a} \right) \times Wpd \times \Delta p$$

Definitions:

- Δp_{rz} — pressure loss at pressure p [Pa]
- ρ_w — specific density of gas related to air
- p_a — base pressure (1,01325 bar)
- p — gauge pressure upstream the meter
- Wpd — coefficient from the diagram below
- Δp — pressure loss [Pa] at Q_{max} from the Table 2

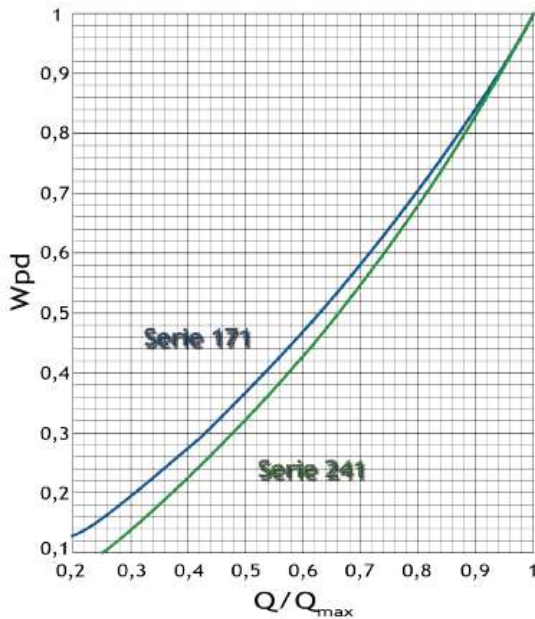

Accessories

- ✓ Thermowells



- ✓ 3-way valve



Table 2: Specification of the rotary gas meters in aluminum and cast iron housings.

DN	G	Max flow Q_{max}	Minimum flow Q_{min} [m ³ /h]							LF pulse rate	HF pulse rate	V cyclic volume	Pressure loss at Q_{max}	Series
			1:50	1:65	1:100	1:160	1:200	1:250	[pulse/m ³]					
ALUMINUM HOUSINGS														
40/50	10	16	0,30	0,25	0,16	—	—	—	10	15390	0,23	75/65	171	
	16	25	0,50	0,40	0,25	0,16	—	—	10	15390	0,23	160/140	171	
	25	40	0,80	0,65	0,40	0,25	0,20	0,16	10	11201	0,31	240/180	171	
40/50/65	40	65	1,30	1,00	0,65	0,40	0,30	0,25	10	7166	0,50	280/210/150	171	
50/65/80	65	100	2,00	1,60	1,00	0,65	0,50	0,40	10	4297	0,81	325/270/200	171	
50/80	100	160	3,20	2,50	1,60	1,00	0,80	0,65	1	2831	1,24	550/395	171	
80/100	100	160	3,20	2,50	1,60	1,00	0,80	0,65	1	1654	1,29	220/190	241	
	160	250	5,00	4,00	2,50	1,60	1,30	1,00	1	1081	2,00	370/280	241	
	250	400	8,00	6,50	4,00	2,50	2,00	1,60	1	645	3,34	580/460	241	
100	400	650	13,00	10,00	6,50	4,00	3,25	2,50	1	645	3,34	1200	241	
CAST IRON HOUSINGS														
40/50	10	16	0,30	0,25	—	—	—	—	10	7166	0,50	33/17	171	
	16	25	0,50	0,40	0,25	—	—	—	10	7166	0,50	45/35	171	
	25	40	0,80	0,65	0,40	0,25	—	—	10	7166	0,50	110/80	171	
40/50/65	40	65	1,30	1,00	0,65	0,40	0,30	0,25	10	4297	0,50	195/150/110	171	
50/65/80	65	100	2,00	1,60	1,00	0,65	0,50	0,40	10	4297	0,81	325/270/200	171	
50/80	100	160	3,20	2,50	1,60	1,00	0,80	0,65	1	2831	1,24	550/395	171	
80/100	100	160	3,20	2,50	1,60	1,00	—	—	1	1081	2,00	180/135	241	
	160	250	5,00	4,00	2,50	1,60	1,30	1,00	1	645	2,00	270/210	241	
	250	400	8,00	6,50	4,00	2,50	2,00	1,60	1	645	3,34	580/460	241	
100	400	650	13,00	10,00	6,50	4,00	3,25	2,50	1	645	3,34	1200	241	

All information included in the table refer to basic version of the meters.

It is possible to manufacture compact version (smaller sizes, higher noise level) and low speed version (bigger sizes, lower noise level).

Contact your local representative or the manufacturer to get more information about the products.